

COLLECTION
LUMINAIRES
2019

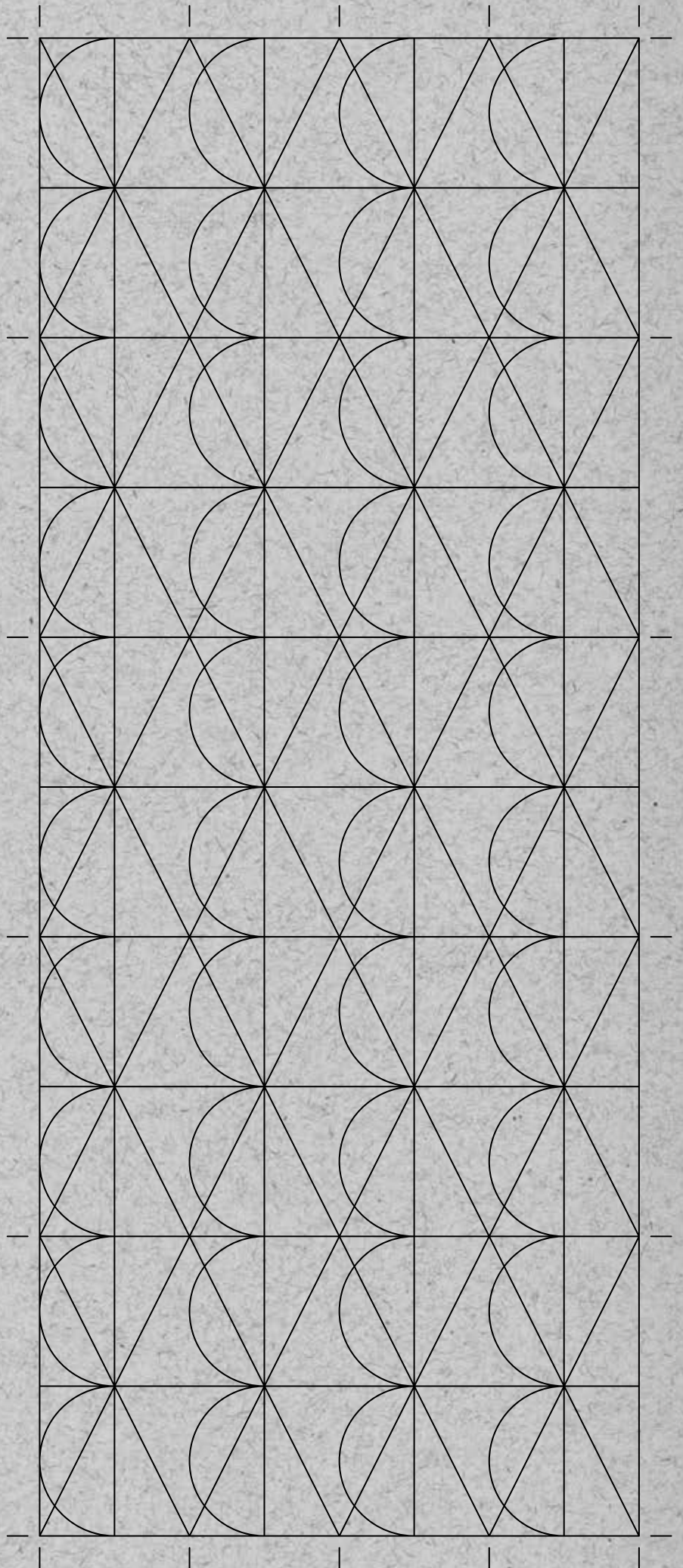

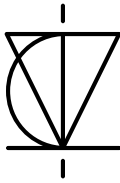





CVL LUMINAIRES, ENTREPRISE SITUÉE DANS LA VALLÉE DE LA LOIRE, SE PRÉVAUT DE PLUS DE CINQ DÉCENNIES D'EXPÉRIENCE DANS LA CRÉATION ET LA FABRICATION DE LUMINAIRES.

L'entreprise assure une fabrication 100% française. D'une part, elle propose une gamme de produits catalogue modulables et adaptables, et possède d'autre part un savoir-faire permettant de réaliser des projets totalement sur-mesure.

Son atout: la flexibilité. L'usine permet une production de l'unité à la série. De plus, l'équipe CVL vous accompagne dans le développement des produits: étude, design, normalisation et production.

Chaque luminaire est entièrement réalisé à la main et met en lumière un savoir-faire de qualité, animé par la passion pour notre matériau de prédilection: le laiton.

Le bureau de création interne, animé par Émilie Cathelineau, designer CVL, collabore depuis plusieurs années avec des designers indépendants tels qu'Hervé Langlais, POOL, Kristian Gavaille et Pauline Deltour.

CVL LUMINAIRES, LOCATED IN THE LOIRE VALLEY, BRINGS OVER FIFTY YEARS OF EXPERIENCE IN THE DESIGN AND PRODUCTION OF HIGH QUALITY LIGHTINGS.

All CVL lightings are 100% manufactured in France. We offer a range of modular and adaptable standard products, and also serve our clients with a unique know-how to design and produce fully customized projects.

Our strength is flexibility: the factory allows to produce both unique products as well as series. Besides, our whole team at CVL helps you through the product design phase: research, design, consulting, standardization and finally, production.

Each light fitting is entirely handmade and highlights CVL's know-how, driven by our passion for our favourite material: brass.

Since several years, the internal design office, managed by Émilie Cathelineau, designer at CVL, collaborates with independent designers like Hervé Langlais, POOL, Kristian Gavaille and Pauline Deltour.

DESIGNERS



ÉMILIE CATHELINEAU

Lorsque qu'Émilie Cathelineau rejoint CVL en tant que designer intégrée en 2003, l'entreprise n'a pas encore de bureau de création. Sa mission : faire évoluer la gamme encore très classique, mais reconnue pour la qualité de ses finitions. Spécialiste du luminaire, elle est la personne de référence pour le développement de produits et fait le lien avec les autres designers. Aujourd'hui, Émilie a plus d'une dizaine de collections à son actif. Déclinées sous toutes les formes de luminaires, elles empruntent leur style autant aux mouvements Art déco qu'au design contemporain.

When Émilie Cathelineau became part of CVL as a designer back in 2003 the company did not yet have a design studio. Her mission was to develop the existing classic range which was known for its quality and various finishes. As an expert in lighting, she is the person in charge for the development of the products and goes over changes and novelties with the other designers. At present, Émilie has designed over ten collections. Made up of all sorts and forms of lights, her collections are inspired from other Art Déco styles to contemporary designs.



PAULINE DELTOUR

Après Olivier de Serres et l'École Nationale Supérieure des Arts Décoratifs de Paris, Pauline Deltour part, durant trois ans, assister à Munich le designer allemand Konstantin Grcic. Elle apprend à ses côtés son métier, envisage de nouvelles méthodes de travail et approfondit son vocabulaire stylistique. En 2011, armée d'une expérience solide, Pauline Deltour revient à Paris et monte son entreprise de design d'objets. Elle collabore également à des projets de scénographie en architecture d'intérieur. En 2017, elle rejoint l'équipe de créateurs de CVL et dessine la collection Signal.

After studying at Olivier de Serres and Paris's famous École nationale supérieure des arts décoratifs, Pauline Deltour assisted the German designer Konstantin Grcic during three years. During her time with him she learnt more about her job, considered new working skills and gained further stylistic vocabulary. In 2011 Pauline Deltour returned to Paris, with even more experience, and set up her own company of designing objects. She also collaborated on stage design projects in interior architecture. In 2017 she joined CVL's designer team and created the Signal collection.



KRISTIAN GAVOILLE

Collaborateur de Philippe Starck durant près de dix ans, Kristian Gavaille, architecte de formation, crée sa propre agence à Paris en 1992. Élu créateur de l'année (toujours en 1992), il est reconnu notamment pour son ouverture d'esprit qui lui permet de s'intéresser à tout, et surtout aux moutons à cinq pattes. Il intervient donc dans de nombreux domaines du design et de l'architecture, où les échanges avec les fabricants et les ouvriers participent au plaisir de la création.

Former colleague of Philippe Starck whom he worked with during nearly ten years, Kristian Gavaille, architect, created his own agency in Paris in 1992. Voted designer of the year (1992), he is known for his open-mindedness which enables him to be interested in everything, including the most weird and wonderful! He intervenes in a lot of domains of design and architecture, where he exchanges views with manufacturers and craftsmen who all take pleasure in creating.



HERVÉ LANGLAIS

Architecte de formation, Hervé Langlais collabore de nombreuses années avec Paul Andreu, spécialiste français des constructions aéroportuaires, et y dessine le Grand Théâtre National de Chine à Pékin ou encore l'Oriental Art Center à Shanghai. Vingt ans plus tard, il retrouve ses premières amours et développe une activité de designer produit. Cet ancien dessinateur de structure accorde une attention particulière aux détails, aux formes épurées et à la rareté des matériaux. Premier designer indépendant à officier pour CVL.

Trained as an architect, Hervé Langlais collaborated for many years with Paul Andreu, a specialist in airport constructions, and together designed the National Centre for the Performing Arts in Beijing in China and even the Shanghai Oriental Art Center. Twenty years later, he started again what he loved doing and developed a product designer activity. This former building designer grants specific importance to each detail, refined form and to the rarity of materials. Hervé is the first independent designer to become part of the CVL team.



POOL

Le studio de création parisien, fondé en 2011 par Léa Padovani et Sébastien Kieffer, intervient autant dans les champs du mobilier, de l'environnement que de l'architecture d'intérieur. Collections signées ou collaborations avec d'autres ateliers et manufactures, le duo POOL réfléchit ses créations dans leur contexte global. La composition géométrique, où formes et couleurs agencent des volumes radicaux, se décline comme une véritable marque de fabrique du tandem transdisciplinaire. Passionnés par les savoir-faire et les rapports humains, ils interviennent régulièrement en tant que directeurs artistiques auprès d'artisans d'art. Tâche que CVL leur a confiée depuis 2017.

The Parisian design studio, founded in 2011 by Léa Padovani and Sébastien Kieffer, intervenes in as many domains as furniture, environment, and interior architecture. The duo POOL studies its creations in a global context, either when signing their own collections or collaborating with other workshops and manufacturers. The geographical composition where forms and colors end up as radical volumes, is the signature of Pool transdisciplinary tandem. Passionate by the know-how of craftsmen and art manufacturers and by human connections, they often act as artistic directors, a role they have had since 2017 for CVL.



INDEX

A

- 16 **Arborescence** Suspensions – Pendants
- 12 **Arborescence** Lampadaires – Floor lamps
- 15 **Arborescence** Lampes de table – Table lamps

C

- 22 **Calé(e)** Suspensions – Pendants
- 31 **Calé(e)** Appliques – Wall lights
- 30 **Calé(e)** Spots
- 34 **Calé(e)** Lampadaires – Floor lamps
- 30 **Calé(e)** Lampes de table – Table lamps
- 36 **Cercle & trait** Suspension – Pendant
- 40 **Constellation** Applique – Wall light
- 47 **Curve** Lampadaire – Floor lamp
- 44 **Curve** Lampe de table – Table lamp

E

- 48 **Earth** Appliques – Wall lights
- 56 **Éclipse** Applique – Wall light
- 60 **Ellis** Lampadaire – Floor lamp
- 63 **Ellis** Lampe de table – Table lamp

F

- 83 **Fléa** Suspension – Pendant
- 82 **Fléa** Applique – Wall light

L

- 66 **Link** Suspension – Pendant
- 64 **Link** Appliques – Wall lights
- 68 **Link** Liseuses – Reading wall lights
- 69 **Link** Lampadaire – Floor lamp
- 69 **Link** Lampe de table – Table lamp
- 76 **Louis** Suspensions – Pendants

Q

- 84 **Quatorze juillet** Suspensions – Pendants
- 86 **Quatorze juillet** Appliques – Wall lights

R

- 88 **Ring** Suspension – Pendant

S

- 92 **Saturne** Suspensions – Pendants
- 96 **Signal** Suspensions – Pendants
- 101 **Signal** Applique – Wall light
- 104 **Solitaire** Lampadaires – Floor lamps
- 108 **Storm** Suspension – Pendant
- 113 **Storm** Applique – Wall light
- 113 **Storm** Lampadaire – Floor lamp
- 113 **Storm** Lampes de table – Table lamps

T

- 116 **Tetra** Applique – Wall light

U

- 122 **Upper** Lampadaire – Floor lamp

W

- 126 **Wok** Applique – Wall light
- 127 **Wok** Lampe de table – Table lamp
- 130 **Wonder** Applique – Wall light
- 130 **Wonder** Lampe de table – Table lamp

**SUSPENSIONS
|
PENDANT LIGHTS**

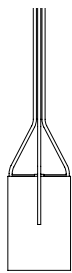

Arborescence
p. 16

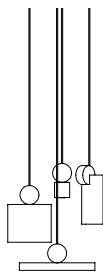

Calé(e)
p. 22

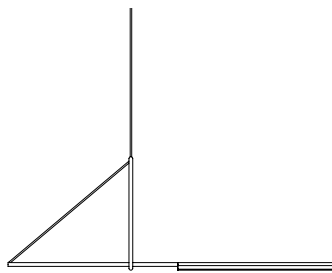

Cercle et trait
p. 36

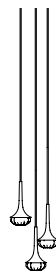

Flea
p. 83

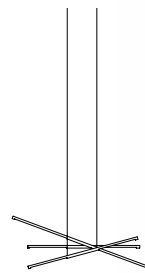

Link
p. 66

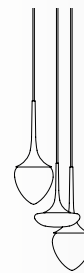

Louis
p. 76

**APPLIQUES
|
WALL LIGHTS**



Calé(e)
p. 31



Calé(e)
p. 30

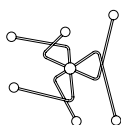

Constellation
p. 40



Earth
p. 48



Eclipse
p. 56



Flea
p. 82



Link
p. 64

**LAMPADAIRES
|
FLOOR LAMPS**

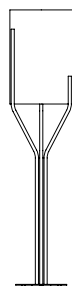

Arborescence
p. 12

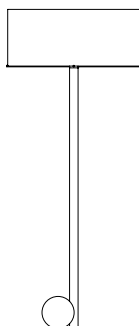

Calé(e)
p. 34

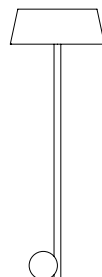

Calé(e)
p. 34



Curve
p. 47

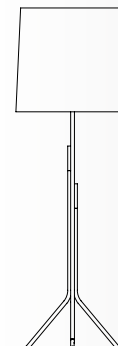

Ellis
p. 60

**LAMPES DE TABLE
|
LAMPS**

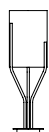

Arborescence
p. 15



Calé(e)
p. 30



Calé(e)
p. 30



Curve
p. 44

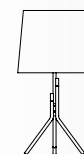

Ellis
p. 63

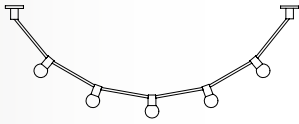

Quatorze juillet
p. 84



Ring
p. 88

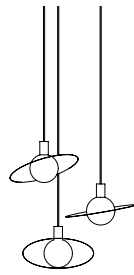

Saturne
p. 92



Signal
p. 96

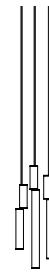

Signal
p. 99

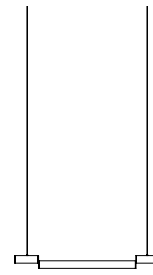

Signal
p. 100

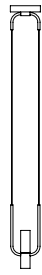

Storm
p. 108

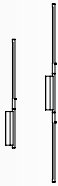

Link
p. 68

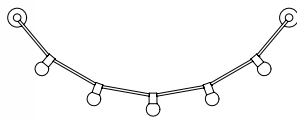

Quatorze juillet
p. 86



Signal
p. 101



Storm
p. 113



Tetra
p. 116



Wok
p. 126



Wonder
p. 130



Link
p. 69



Solitaire
p. 104

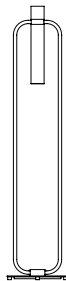

Storm
p. 113

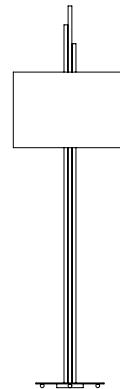

Upper
p. 122



Link
p. 69



Storm
p. 111



Wok
p. 127



Wonder
p. 130











ARBORESCENCE

Collection ouverte, *Arborescence* est une gamme complète qui se décline en différentes dimensions. Évolutive, vous avez la possibilité de vous orienter sur du sur-mesure.



One of our most popular collections, *Arborescence* is a complete range in a variety of sizes and finishes. As a flexible concept, you can customize the light into a bespoke product.

**Finitions
Finishes**

 Laiton satiné SB Satin brass	 Graphite satiné SG Satin graphite	 Nickel satiné SN Satin nickel	 Cuivre satiné SC Satin copper
 Laiton poli PB Polished brass	 Graphite poli PG Polished graphite	 Nickel poli PN Polished nickel	 Cuivre poli PC Polished copper



**Abat-jour
Lampshade**

 Drop Paper® 100	 Drop Paper® 101	 Drop Paper® 103
---	---	---

**Matériaux
Material**

Tous – All Laiton massif Solid Brass	Tous – All Abat-jour Drop Paper® M1 Lampshade Drop Paper® M1	Lampes de table – Table lamps Câble textile noir (longueur ≈ 2 m) Black textile cable (length ≈ 79")
---	---	---

**Source
Lamping**

Suspensions – Pendant lights 1 x E27 205 W max. Ampoule non fournie 1 x E27 205 W max. Bulb not included		Variation* Dimming*	
1 x E26 type A 150W. Bulb not included			
Lampadaires – Floor lamps 1 x E27 205 W max. Ampoule non fournie 1 x E27 205 W max. Bulb not included	Variateur à pied Foot operated dimmer	Variation* Dimming*	
1 x E26 type A 150W. Bulb not included	Foot operated switch		
Lampes de table – Table lamps 1 x E27 105 W max. Ampoule non fournie 1 x E27 105 W max. Bulb not included	Interrupteur sur câble Cable switch		
1 x E26 type A 100W. Bulb not included	Cable switch		

Designer

Hervé Langlais

* Les luminaires variables nécessitent l'utilisation d'ampoules compatibles avec la variation
All dimmable light fixture require the use of compatible bulbs

Lampe de table – Table lamp XS

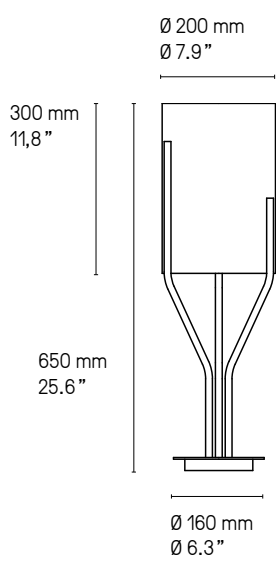

Lampe de table – Table lamp Arborescence XS SB

Suspension – Pendant L

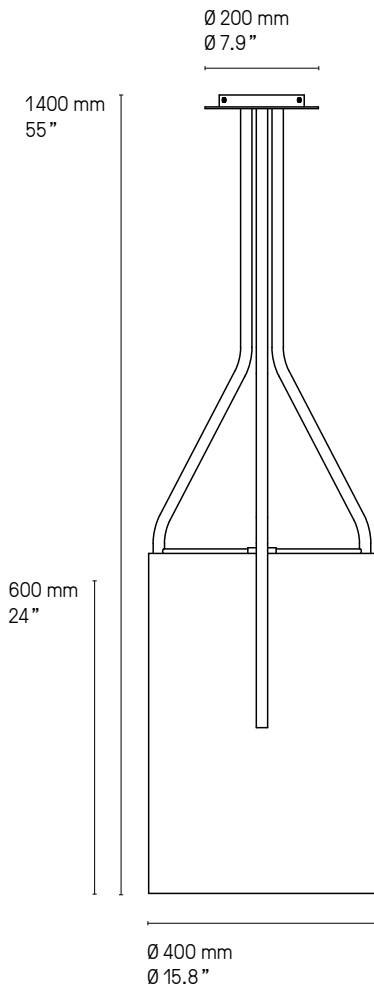

Suspension – Pendant XL

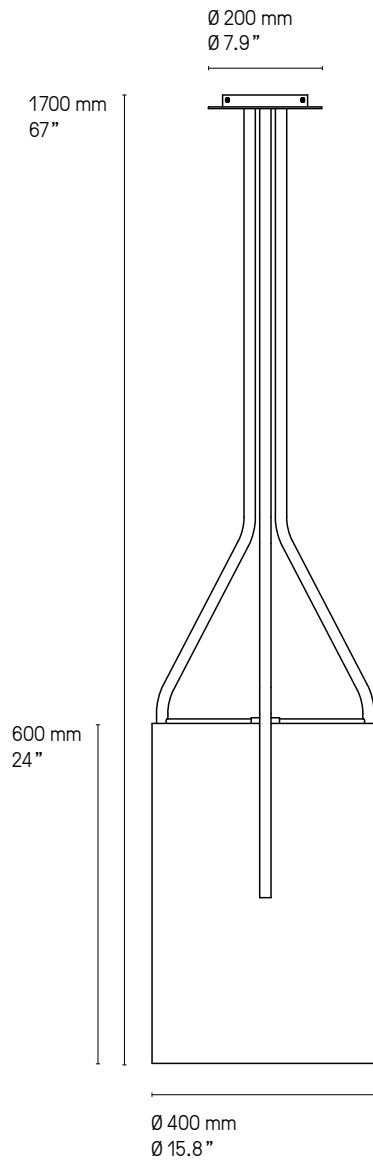

Suspension – Pendant XXL

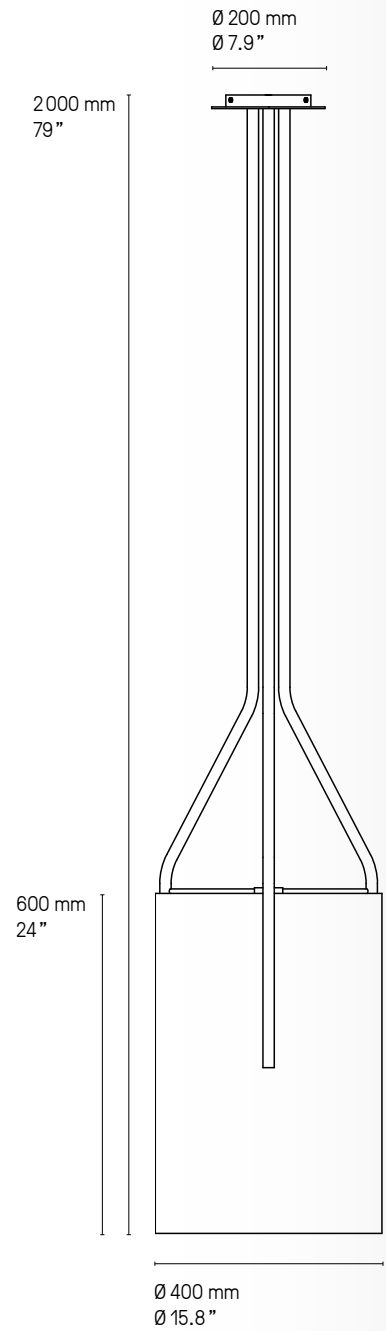

Hauteur sur mesure, version LED et DALI sur demande.
Custom heights, LED and DALI version upon request.

Suspension – Pendant XXS

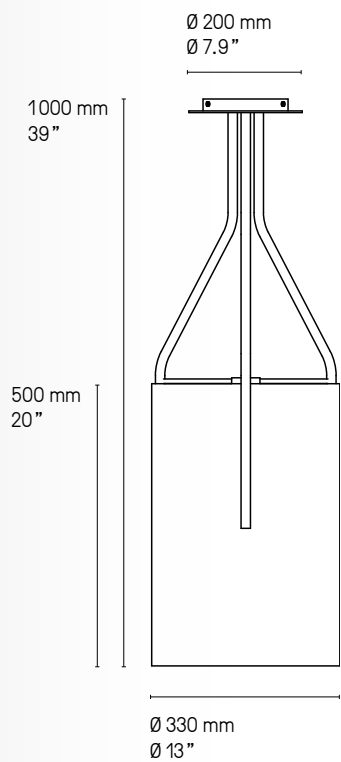

Suspension – Pendant XS

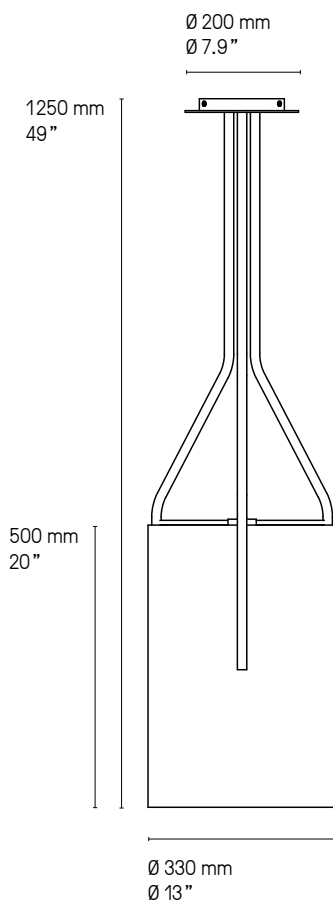

Suspension – Pendant S

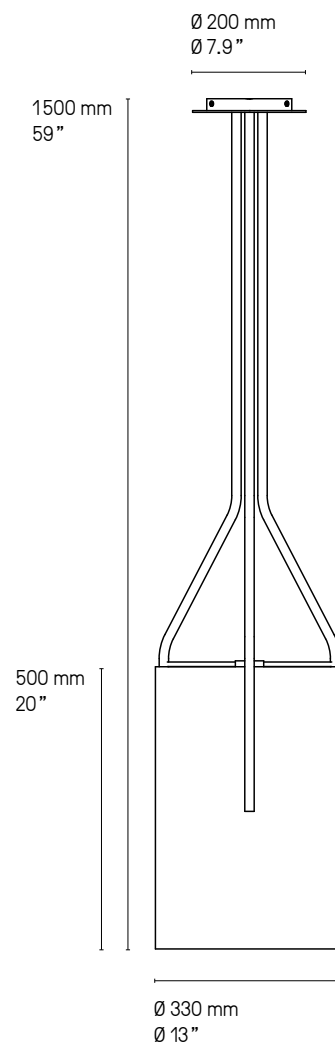

Hauteur sur mesure, version LED et DALI sur demande.
Custom heights, LED and DALI version upon request.

Lampadaire – Floor lamp L

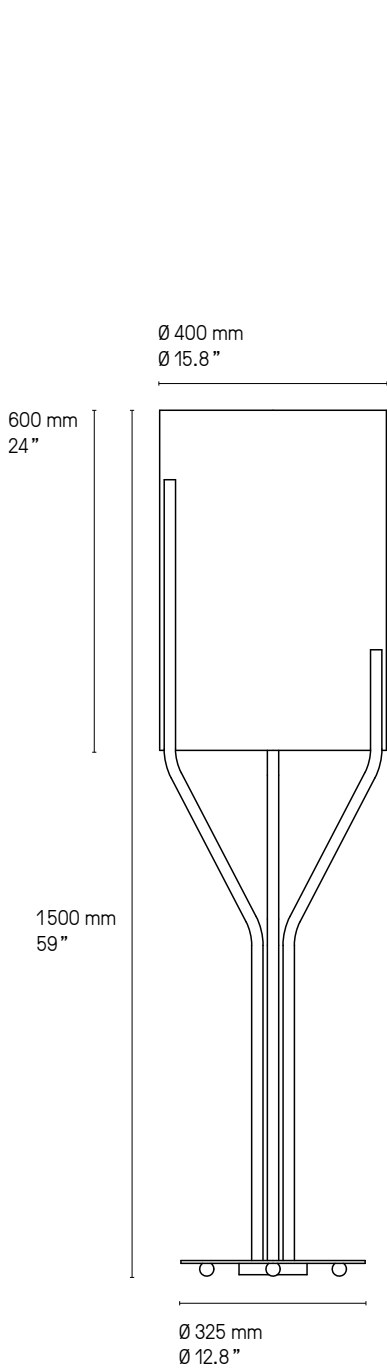

Lampadaire – Floor lamp XL

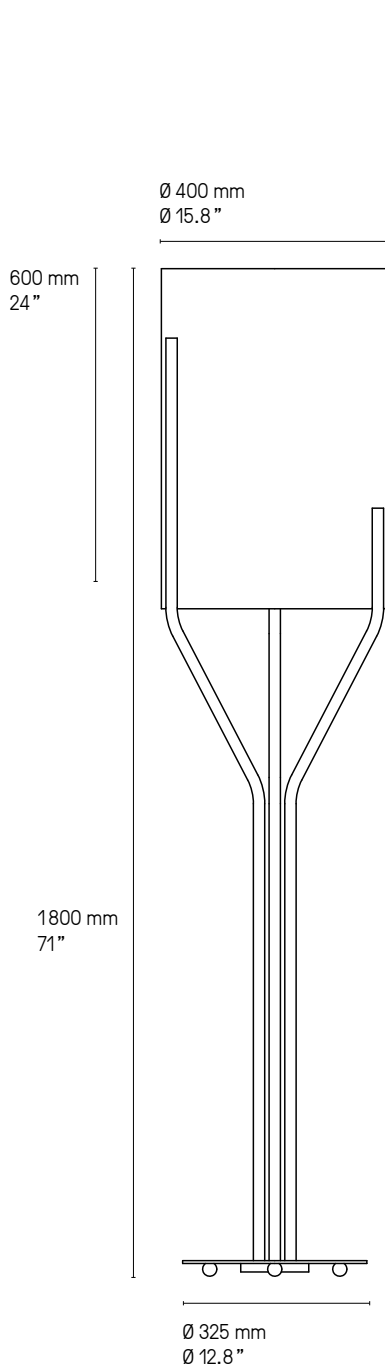

Lampadaire – Floor lamp XXL

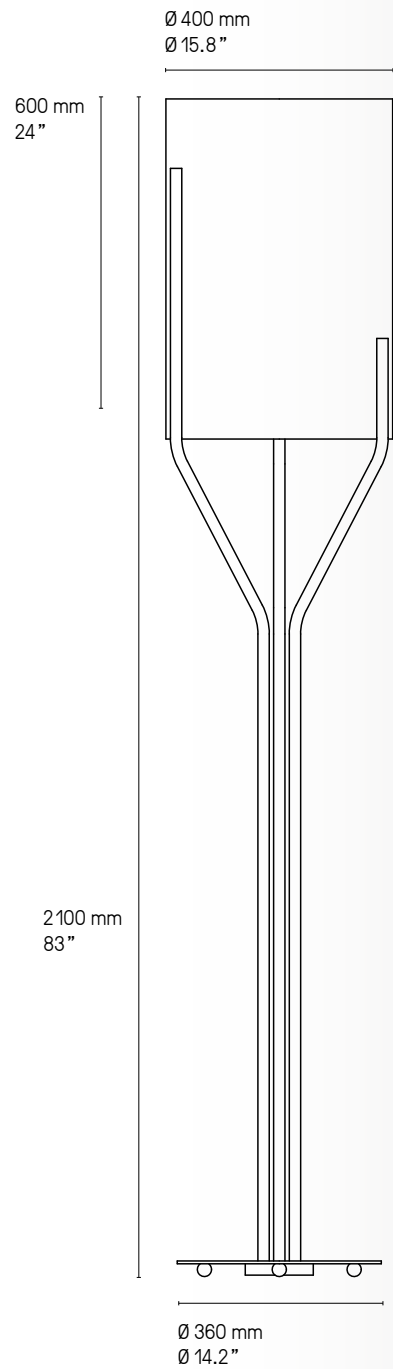

Hauteur sur mesure, version LED et DALI sur demande.
Custom heights, LED and DALI version upon request.

Lampadaire – Floor lamp **XXS**

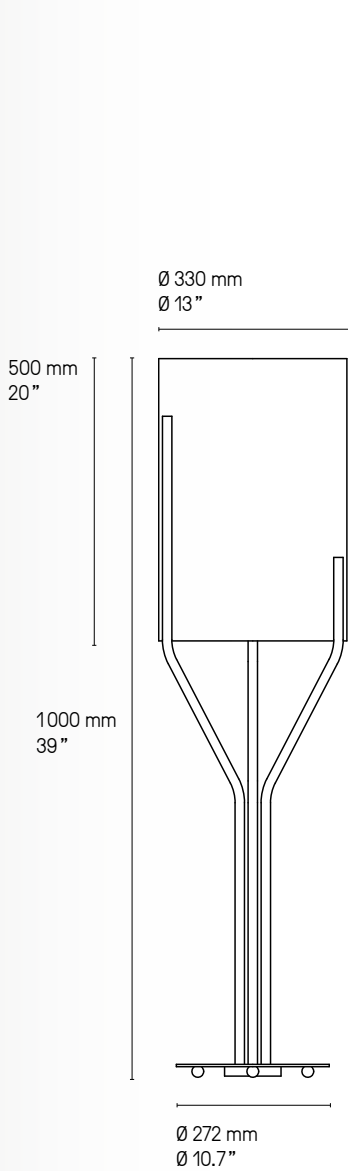

Lampadaire – Floor lamp **XS**

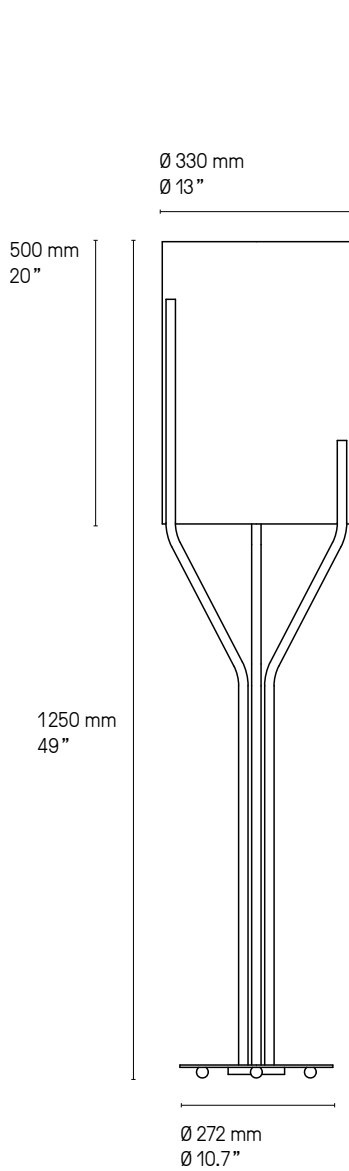

Lampadaire – Floor lamp **S**

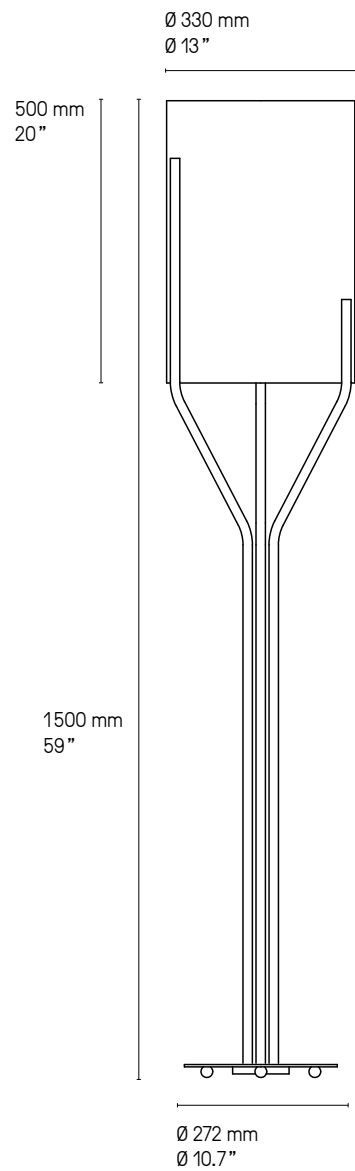

Hauteur sur mesure, version LED et DALI sur demande.
Custom heights, LED and DALI version upon request.



Suspensions - Pendants Arborescence Hauteur sur mesure / Custom height SB





CALÉ(E)

Alphabet de formes, la collection *Calé(e)* se décline en jeu géométrique où le sens du déséquilibre forme des objets simples, linéaires et raffinés.



An assembly of designs, the *Calé(e)* collection offers a range of geometric patterns where the sense of imbalance forms simple, linear and sophisticated objects.





Finitions Finishes

① + ②

Suspensions, lampes de table, lampadaires – Pendants, table and floor lamps

 Laiton satiné SB Satin brass	 Graphite satiné SG Satin graphite	 Nickel satiné SN Satin nickel	 Cuivre satiné SC Satin copper
---	--	--	--

Appliques – Wall mounted lights

 Laiton satiné SB Satin brass	 Graphite satiné SG Satin graphite	 Nickel satiné SN Satin nickel	 Cuivre satiné SC Satin copper
---	--	--	--

 Laiton poli PB Polished brass	 Graphite poli PG Polished graphite	 Nickel poli PN Polished nickel	 Cuivre poli PC Polished copper
--	---	---	---

Abat-jour Lampshade

Lampadaires, lampes de table – Table and floor lamps

 Chinette noire Black chinette	 Chinette blanche White chinette
--	--

Câble Cable

Suspensions – Pendants

 Tissu noir Black textile	 Tissu or Gold textile
---	--

Matériaux Material

Tous – All
Laiton massif
Solid Brass

Suspensions, appliques, lampe XL
Pendants, wall lights, table lamp XL
Diffuseur en polycarbonate
Polycarbonate diffuser

Lampe de table XS, lampadaires
Table lamp XS, floor lamps
Abat-jour en tissu
Textile lampshade

Suspensions, lampes, lampadaires
Pendants, table & floor lamps
Câble textile (longueur ≈ 2 m)
Textile cable (length ≈ 79")

*La longueur standard des câbles est de 2 mètres
mais elle peut être diminuée à l'installation.
The standard height of the cables is 2 meters (79")
but can be adjusted to less during installation.*

Description Features

Suspensions – Pendants

Il est possible de rassembler plusieurs suspensions sur un seul pavillon, circulaire ou rectangulaire. La version rectangulaire peut être adaptée à n'importe quelle longueur. La version circulaire a un diamètre maximum indiqué sur les croquis ci-après. Pour plus de renseignements, veuillez nous contacter.

It is possible to cluster several pendants from one single canopy, either rectangular or circular. The rectangular canopy can be custom-made into any size to suit your requirements. As for the circular canopy, available sizes are illustrated in the following pages. Please contact us for further information.

Designer

POOL

**Source
Lamping**

Suspensions – Pendants

Suspension – Pendant V1

LED intégrée 500 lm 2700°K
Integrated LED 500 lm 2700°K

Alim. électronique 24 V intégrée
Int. power supply 24 V included

Variation. Veuillez nous contacter
Dimming. Please, contact us



Suspension – Pendant V2

LED intégrée 900 lm 2700°K
Integrated LED 900 lm 2700°K

Alim. électronique 24 V intégrée
Int. power supply 24 V included

Variation. Veuillez nous contacter
Dimming. Please, contact us



Suspension – Pendant V3

LED intégrée 630 lm 2700°K
Integrated LED 630 lm 2700°K

Alim. électronique 24 V intégrée
Int. power supply 24 V included

Variation. Veuillez nous contacter
Dimming. Please, contact us



Suspension – Pendant V4

LED intégrée 1500 lm 2700°K
Integrated LED 1500 lm 2700°K

Alim. électronique 24 V intégrée
Int. power supply 24 V included

Variation. Veuillez nous contacter
Dimming. Please, contact us



Appliques – Wall lights

Appliques – Wall light V1, 2 & 3

LED intégrée 960 lm 2700°K
Integrated LED 960 lm 2700°K

Alim. électronique 24 V intégrée
Int. power supply 24 V included

Spot XL

LED intégrée 700 lm 2700°K
Integrated LED 700 lm 2700°K

Alim. électronique intégrée
Int. power supply included

Not available for 110V

Lampes de table – Table lamps

Lampe – Lamp XL

LED intégrée 1700 lm 2700°K
Integrated LED 1700 lm 2700°K

Alim. électronique intégrée
Int. power supply included

Lampe – Lamp XS

1 X E14 60 W max. Ampoule non fournie
1 X E14 60 W max. Bulb not included

Interrupteur sur câble
Cable switch

Lampadaires – Floor lamps XL

1 X E27 205 W max. Ampoule non fournie
1 X E27 205 W max. Bulb not included

Variateur à pied
Foot operated dimmer

Variation*
Dimming*

Lampadaires – Floor lamps XS

1 X E27 105 W max. Ampoule non fournie
1 X E27 105 W max. Bulb not included

Variateur à pied
Foot operated dimmer

Variation*
Dimming*

* Les luminaires variables nécessitent l'utilisation d'ampoules compatibles avec la variation
All dimmable light fixture require the use of compatible bulbs

V1

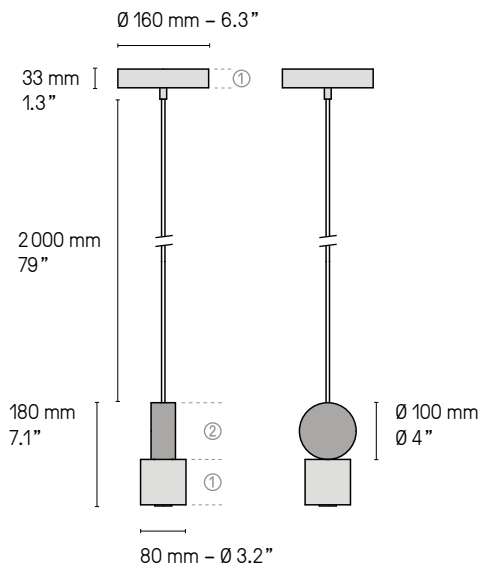

V2

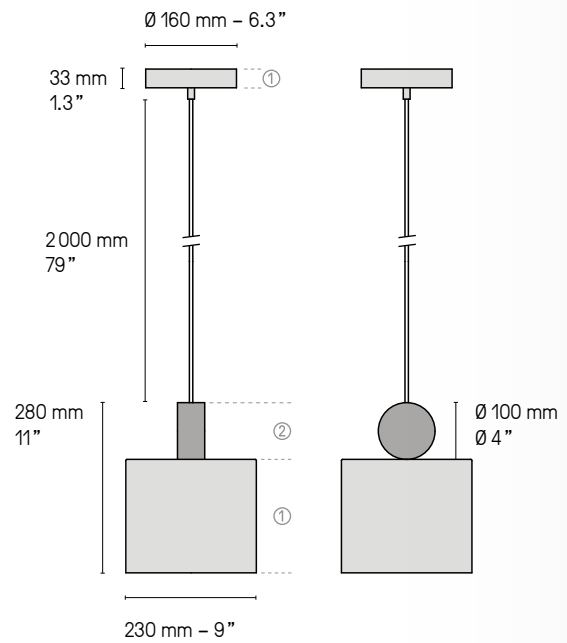

V3

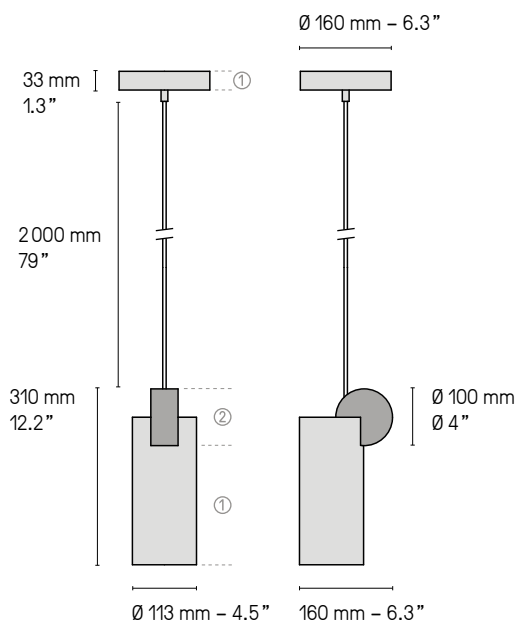

V4

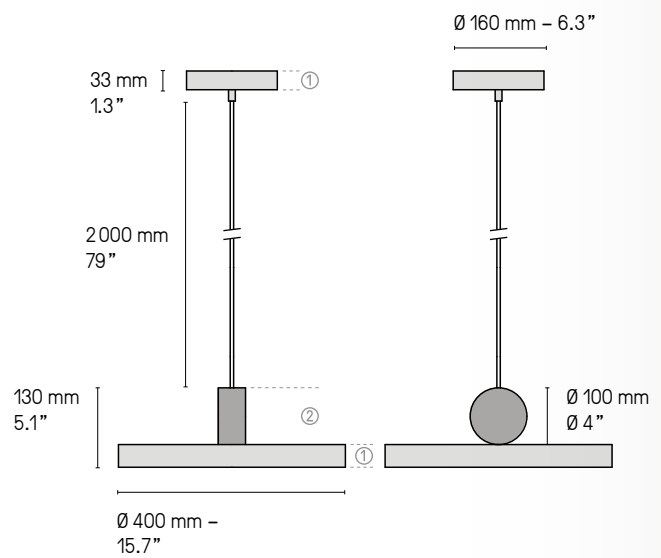

Le petit disque du dessous sera toujours en finition ①
 The small centered disc on the bottom always comes in finish ①

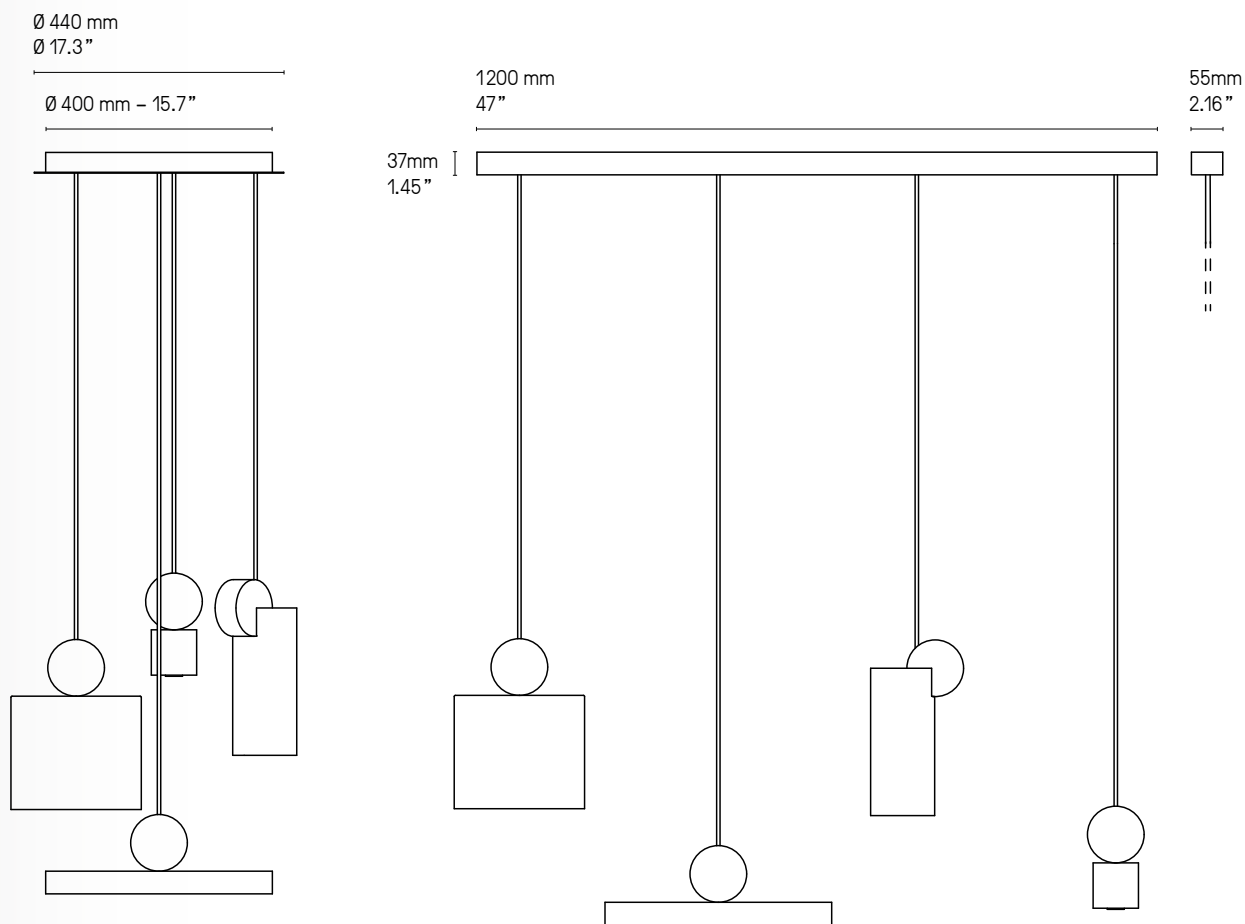

Calé(e) V3 & V4 SB/SG

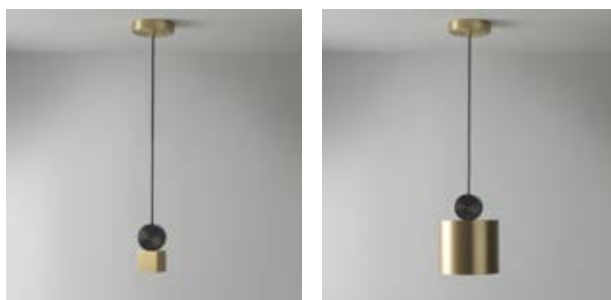

Calé(e) V1 & V2 SB/SG





Suspension Calé(e) V1 SB/SG



Spot Calé(e) XL SB/SG



Lampe Calé(e) XS SN/SG



Lampe Calé(e) XL SB/SG

Appliques – Wall lights Calé(e)

V1

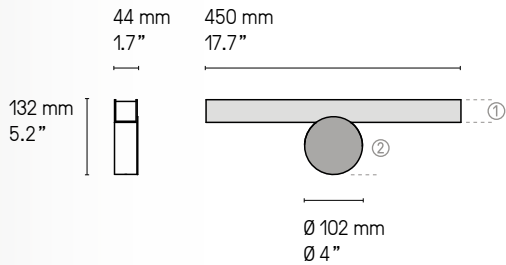

V2

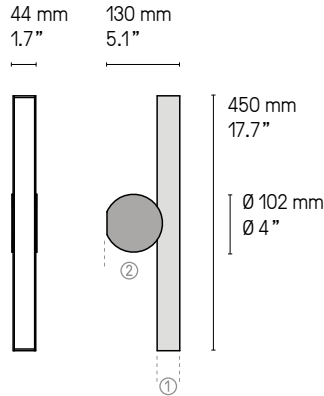

V3

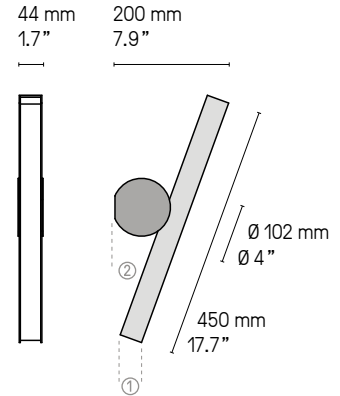

Les appliques Calé(e)s ne sont pas réglables. Ce sont 3 modèles différents.
Calé(e) wall lights are not mobile. These are 3 different fixed models.

Spot XL

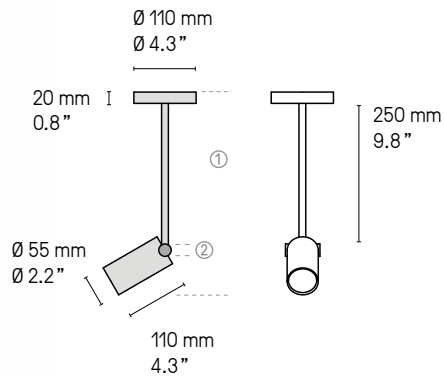

Lampe de tables – Table lamps Calé(e)

XL

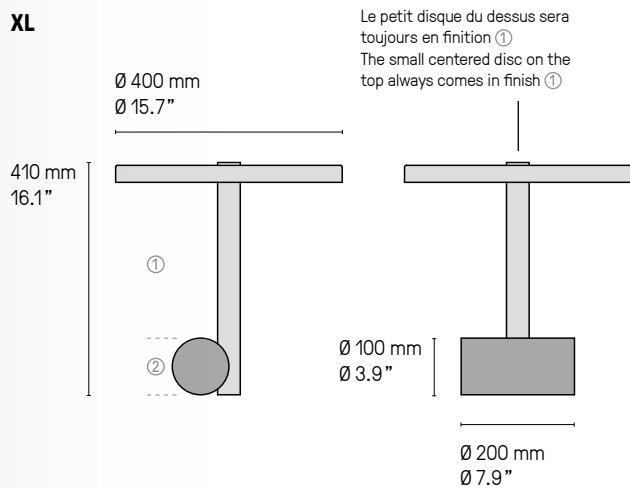

XS

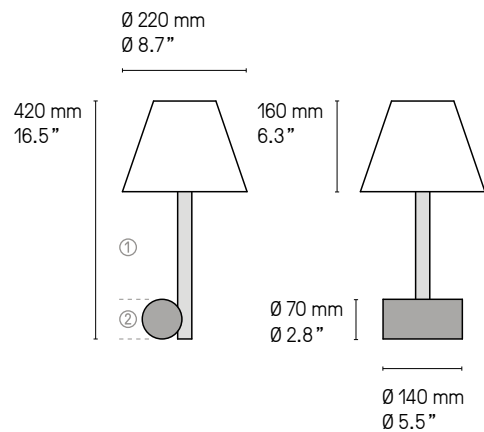





Applique – Wall light Calé(e) V3 SB/SG



Applique – Wall light Calé(e) V2 SG/SB



Applique – Wall light Calé(e) V1 SB/PB

Lampadaires – Floor lamp Calé(e)

XL

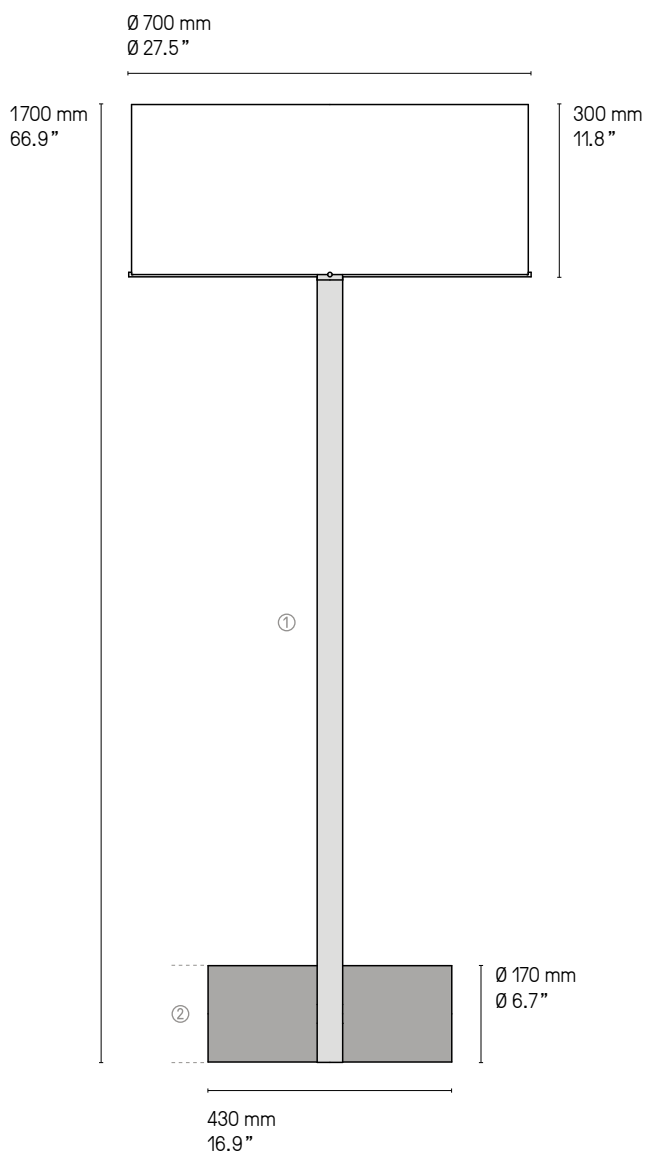

XS

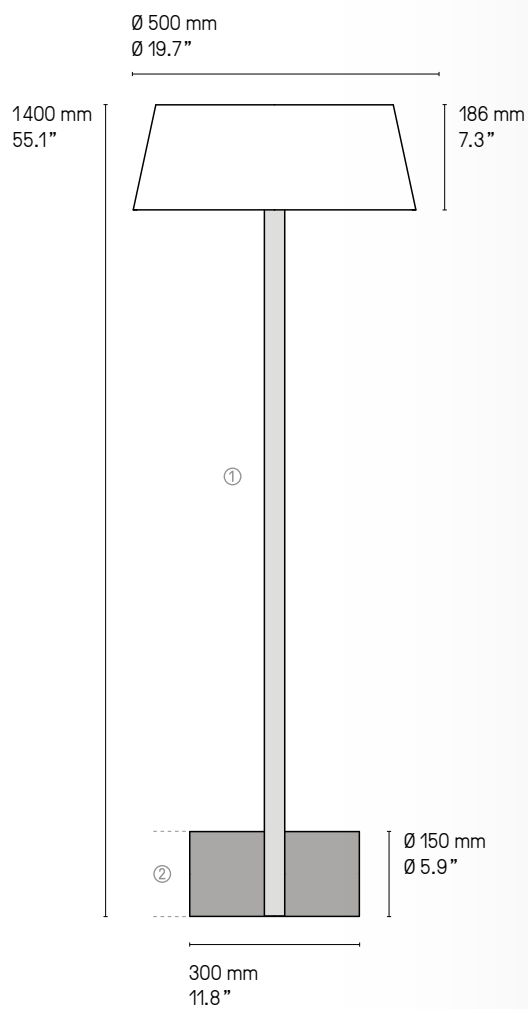

Version LED et DALI sur demande.
 LED and DALI version upon request.



Lampadaire – Floor lamp Calé(e) XS SB



CERCLE & TRAIT

D'une apparente légèreté, les formes de *Cercle & trait* se frottent et se tiennent dans un jeu d'équilibre savamment dosé. Une suspension graphique déclinée en différentes finitions qui ne tient qu'à un fil.



As light as it looks, the forms of *Cercle & trait* rub together and hold together in a cleverly measured balance. A graphic pendant, available in different finishes, is just held by one small wire.

**Finitions
Finishes**

● Laiton satiné
SB Satin brass

● Graphite satiné
SG Satin graphite

● Nickel satiné
SN Satin nickel

● Cuivre satiné
SC Satin copper

**Matériaux
Material**

Laiton massif
Solid Brass

Diffuseur en polycarbonate blanc
White polycarbonate diffuser

Câble textile noir (longueur ≈ 1 m)
Black textile cable (length ≈ 39.4")

**Source
Lamping**

LED 1400 lm 2700°K
LED 1400 lm 2700°K

Alim. 24V intégrée dans le pavillon
Int. power supply 24V included in canopy

Variable (phase cut)
Dimmable (phase cut)



Designer

POOL

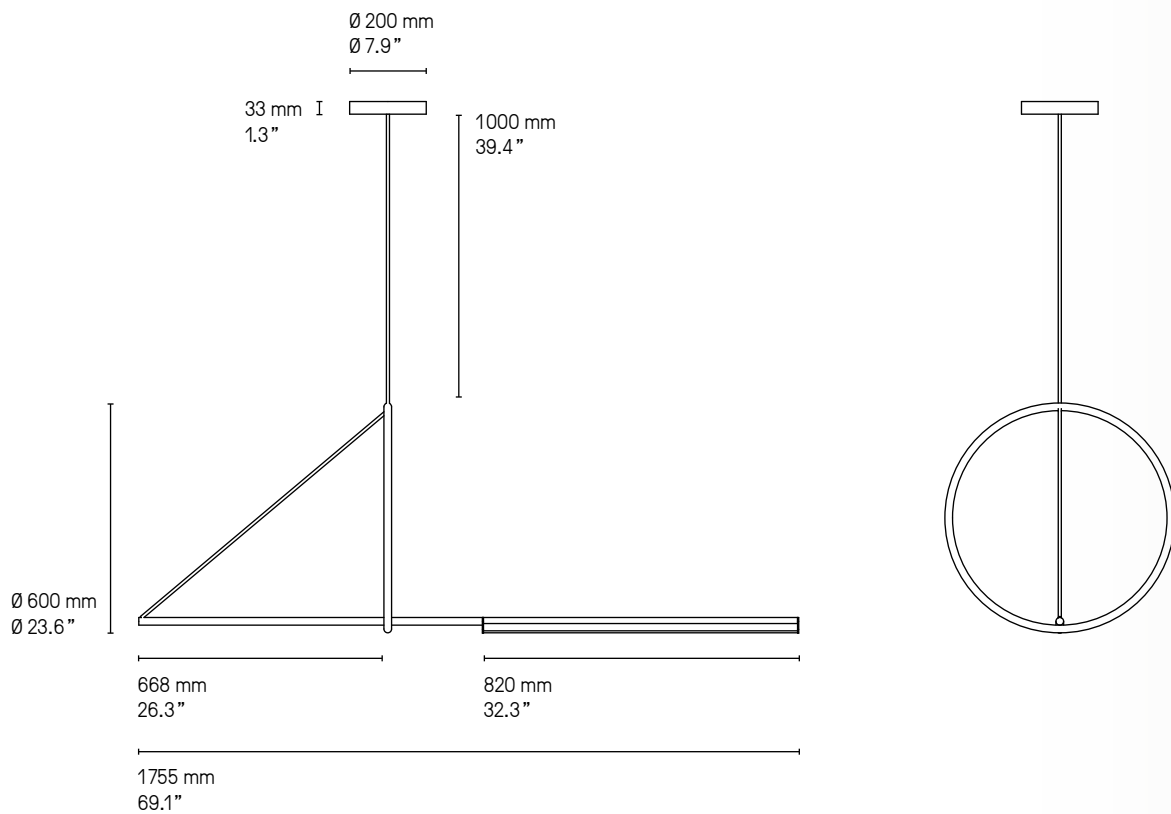



Cercle & trait SG



CONSTELLATION

Asymétrie et démultiplication, *Constellation* offre une infinité de possibilités à composer selon l'espace et vos inspirations. En mural ou au plafond, vos envies se dessinent en points lumineux.



Asymmetry and multiplying, *Constellation* offers an infinity of arrangement possibilities depending on the space and your inspirations. As a wall unit or a ceiling fixture, you can position the light any way you desire to.

Finitions
Finishes ①

● Laiton satiné	● Graphite satiné	● Nickel satiné
SB Satin brass	SG Satin graphite	SN Satin nickel

Finitions
Finishes ②

● Laiton satiné	● Graphite satiné	● Nickel satiné	● Cuivre satiné
SB Satin brass	SG Satin graphite	SN Satin nickel	SC Satin copper

Matériaux
Material

Laiton massif	Verre triplex opale soufflé bouche
Solid Brass	Opal triplex mouth-blown glass

Source
Lamping

LED intégrée	6 x 120 lm	3000° K	Alimentation intégrée fournie	Variation. Veuillez nous contacter
Integrated LED	6 x 120 lm	3000° K	Integrated power supply included	Dimming. Please, contact us
			ou - or	
			Alimentation séparée fournie	
			Remote power supply included	



Designer

Émilie Cathelineau

Alimentation intégrée
Integrated power supply

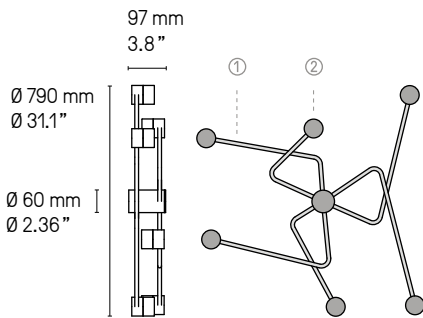

Alimentation séparée
Remote power supply

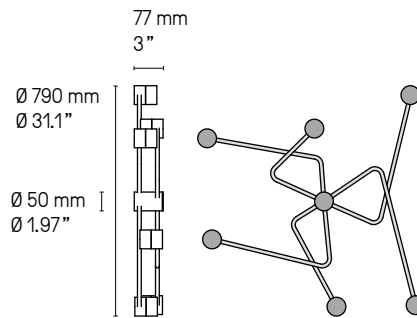

UL Version
fitted plate to cover outlet power box

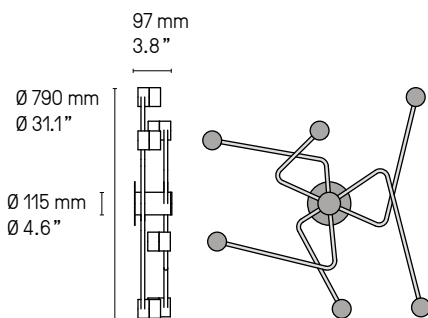

Exemples de compositions, avec 3, 5 et 8 modules
Examples of arrangements, with 3, 5 or 8 units

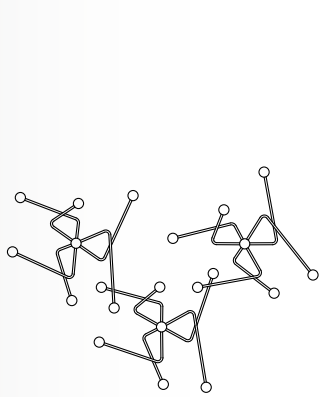

x 3

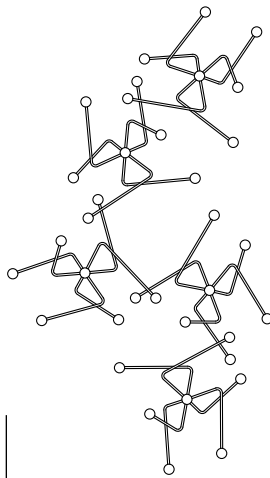

x 5

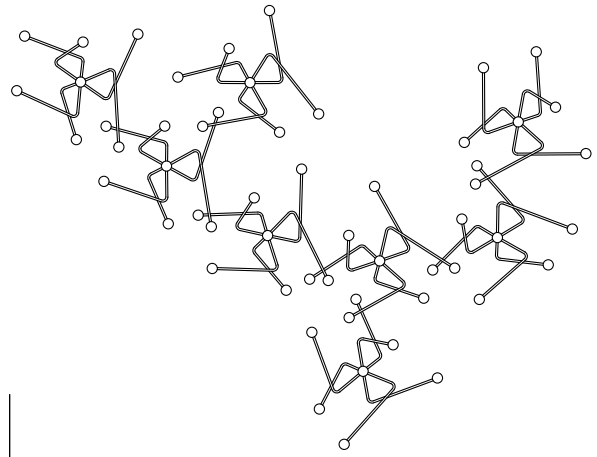

x 8

Version interconnectée
Interconnected version

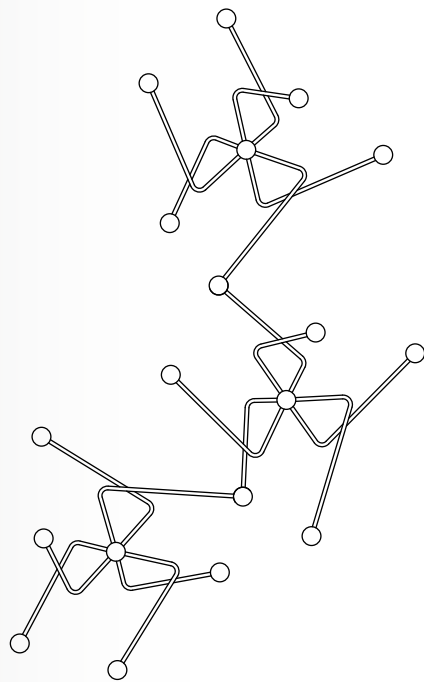

Ce système d'interconnection ne nécessite qu'une seule sortie électrique. Veuillez noter que cette version interconnectée n'est pas certifiée UL et que les points de connections ne sont pas lumineux. Merci de nous contacter pour connaître les compositions possibles.

The new interconnection system requires only one electrical outlet. Please be aware that this interconnected system is not yet UL certified and that the connection points have no light. Contact us for more information on possible arrangements.











CURVE

Trois formats viennent composer cette collection aux lignes singulières. Les deux lampadaires et la lampe *Curve* s'agencent autour d'un abat-jour triangulaire incurvé prolongé par la ligne du pied.



The lights of this collection are each composed of three formats with unique lines. Both the *Curve* floor lamps and Lamp arrange themselves around a triangular curved lampshade.

**Finitions
Finishes**

 Laiton satiné SB Satin brass	 Graphite satiné SG Satin graphite	 Nickel satiné SN Satin nickel	 Cuivre satiné SC Satin copper
 Laiton poli PB Polished brass	 Graphite poli PG Polished graphite	 Nickel poli PN Polished nickel	 Cuivre poli PC Polished copper



**Abat-jour
Lampshade**

 Duke	 Chinette blanche White chinette
--	--

**Matériaux
Material**

Laiton massif Solid Brass	Abat-jour tissu Textile lampshade	Câble textile noir (longueur ≈ 2 m) Black textile cable (length ≈ 79")
------------------------------	--------------------------------------	---

**Source
Lamping**

Lampadaire – Floor lamp			
1 x E27 205 W max. Ampoule non fournie		Variateur à pied	Variation*
1 x E27 205 W max. Bulb not included		Foot operated dimmer	Dimming*
1 x E26 type A 100 W. Bulb not included		Foot operated switch	
Lampe de table – Table lamp			
1 x E27 60 W max. Ampoule non fournie		Interrupteur sur câble	
1 x E27 60 W max. Bulb not included		Cable switch	
1 x E26 type A 60 W. Bulb not included		Cable switch	

Designer

Émilie Cathelineau

* Les luminaires variables nécessitent l'utilisation d'ampoules compatibles avec la variation
All dimmable light fixture require the use of compatible bulbs

Curve lampe de table – Table lamp

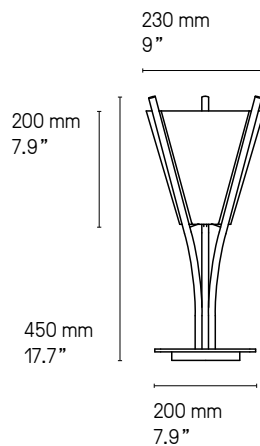

Curve XL

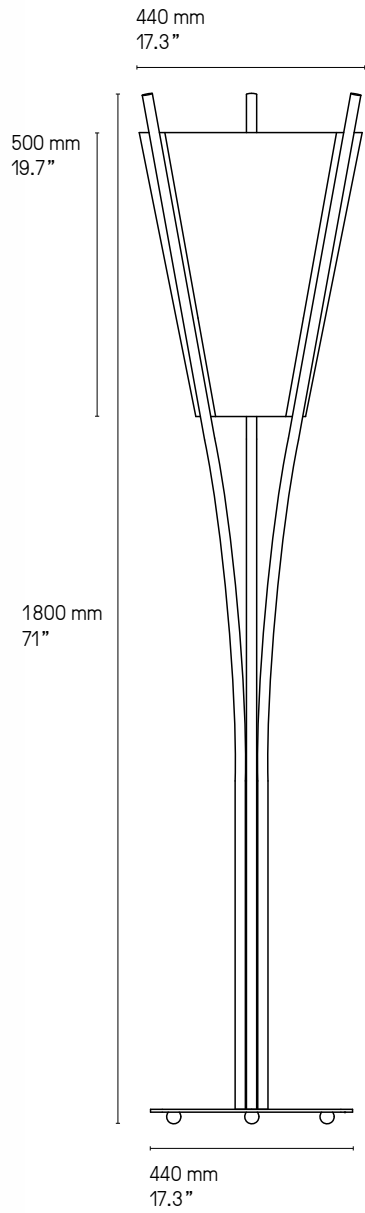

Curve XS

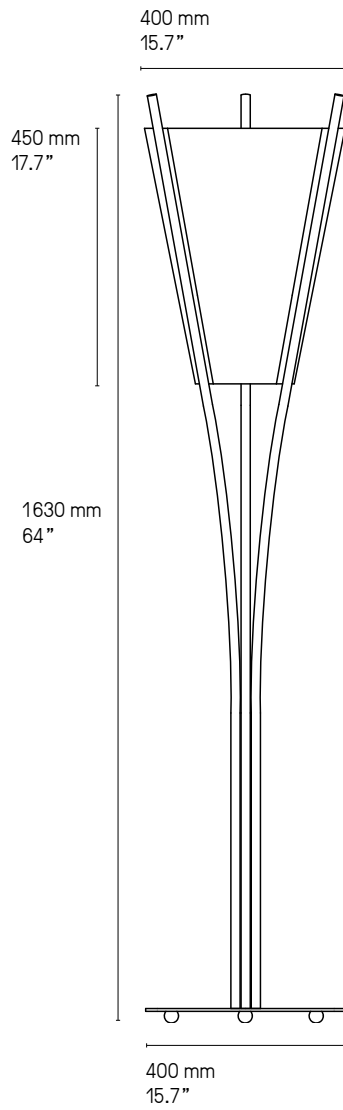

Version LED et DALI sur demande.
LED and DALI version upon request.



EARTH

Un cœur lumineux, serti d'un métal ajouré de manière extrêmement fine ou d'un disque plein, confère à cette collection une touche Art déco. Du clair-obscur au moucharabieh, les idées de composition sont variées.



This wall light, with an illuminated center, assembled with an extremely fine openwork or a fully covered piece of metal gives this collection an Art déco style. From semi-darkness to a patterned light source, arrangements can vary.

Finitions
Finishes ①+②

● Laiton satiné
SB Satin brass

● Graphite satiné
SG Satin graphite

● Nickel satiné
SN Satin nickel

● Cuivre satiné
SC Satin copper

Matériaux
Material

Laiton massif
Solid brass

Diffuseur en polycarbonate
Polycarbonate diffuser

Source
Lamping

LED intégrée
Integrated LED

1080 lm 2700°K
1080 lm 2700°K

Alim. électronique 24 V intégrée
Integrated 24 V power supply

Variation. Veuillez nous contacter
Dimming. Please, contact us



Designer

Émilie Cathelineau

Earth Sober

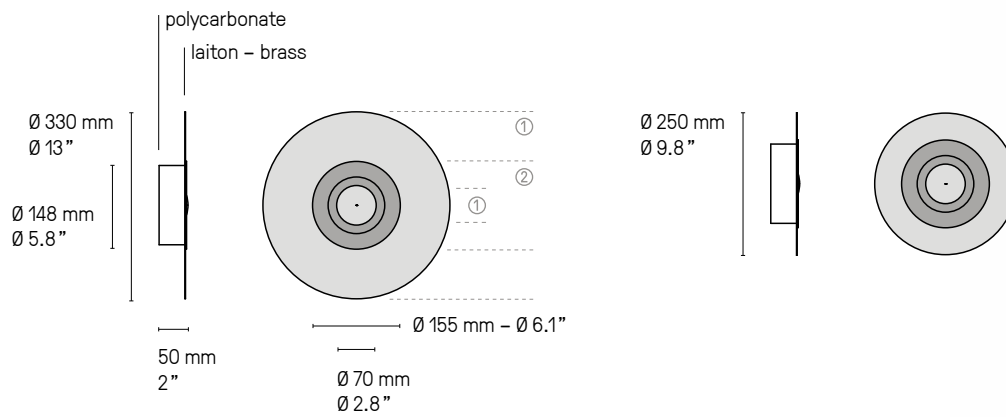

Partie centrale identique pour tous les modèles, quels que soient la taille et le motif.
Identical central part for all *Earth* fixtures for any size and design.

Earth Sun

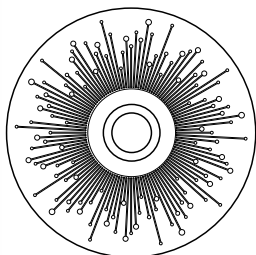

Ø 440 mm
Ø 17.3"

Disponibile en Ø 330 mm
Available in Ø 13"

Earth Palm

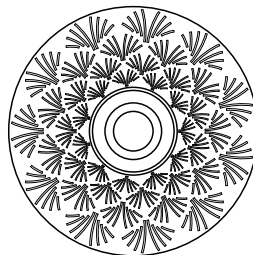

Ø 440 mm
Ø 17.3"

Disponibile en Ø 330 mm
Available in Ø 13"

Earth Mandala

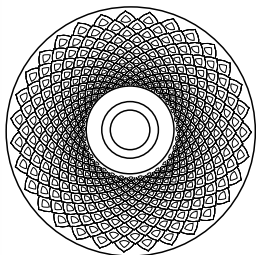

Ø 440 mm
Ø 17.3"

Disponibile en Ø 330 mm
Available in Ø 13"

Earth Turtle

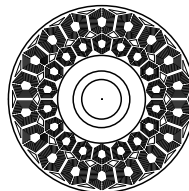

Ø 330 mm
Ø 13"

Disponibile en Ø 440 mm
Available in Ø 17.3"

Earth Radian

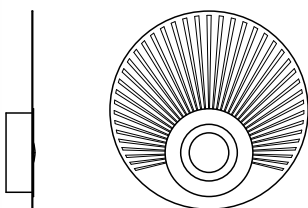

Ø 350 mm
Ø 13.8"



Earth Sober 330 SB/SG



Earth Radian 350 SB/SG

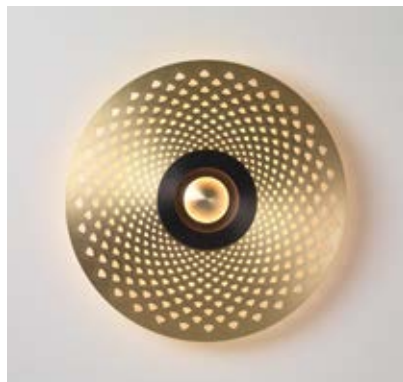

Earth Mandala 440 SB/SG



Earth Sun 440 SB/SG



Earth Palm 330 SB/SG



Earth Sun 330 SC/SG





Earth Turtle 330 SG/SB





ÉCLIPSE

Série d'appliques déclinée en deux diamètres, *Éclipse* joue de disparition entre sa dalle de led et ses deux disques de laiton. Un objet céleste qui ensoleille les architectures.



Éclipse, a wall light available in two diameters in which a led plate is hidden in between two brass discs. A celestial object that stuns architectures.

**Finitions
Finishes** ①+②

● Laiton satiné
SB Satin brass

● Graphite satiné
SG Satin graphite

● Nickel satiné
SN Satin nickel

● Cuivre satiné
SC Satin copper

En standard, le petit disque au centre du produit sera toujours en finition (①) polie.
Si vous préférez une finition satinée, merci de le préciser.
The small centered disc on the front always comes in a polished finish (①) but can
be in satin if specified.

**Matériaux
Material**

Laiton massif
Solid Brass

**Description
Features**

L'applique *Éclipse* est fixe. Une fois positionnée au mur, elle ne peut pas tourner.
Please be aware that discs are fixed and cannot be positioned in any other way.

**Source
Lamping**

LED intégrée	1790 lm	3000°K	Alim. électronique intégrée	Variation. Veuillez nous contacter
Integrated LED	1790 lm	3000°K	Integrated power supply	Dimming. Please, contact us

Designer

Hervé Langlais

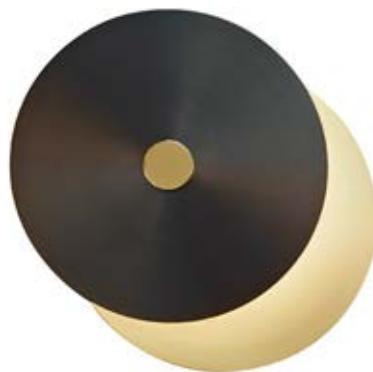

Eclipse SB/SG

Éclipse XL

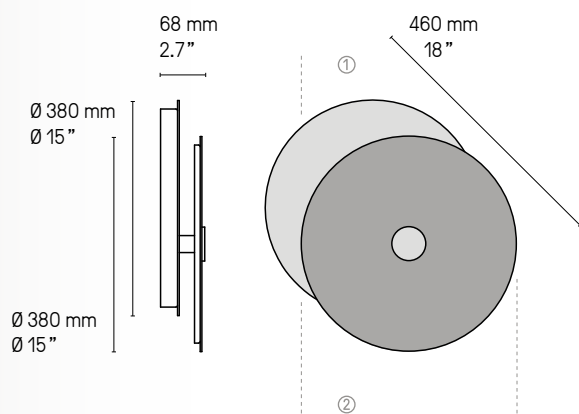

Éclipse XS

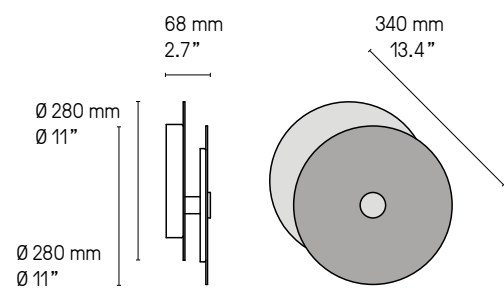











ELLIS

Empiètement des années 30 revisité pour ce lampadaire à l'allure classique, mais aux détails résolument contemporains. Les embouts polis, qui viennent finir la ligne en bout de tube, sont personnalisables à la demande.



A step back in time for this remake of a classical 1930's floor lamp, redesigned with contemporary details. The polished tips at the end of each brass tubes are customizable on request.

Finitions
Finishes ①+②

 Laiton satiné SB Satin brass	 Graphite satiné SG Satin graphite	 Nickel satiné SN Satin nickel	 Cuivre satiné SC Satin copper
 Laiton poli PB Polished brass	 Graphite poli PG Polished graphite	 Nickel poli PN Polished nickel	 Cuivre poli PC Polished copper



Abat-jour
Lampshade

 Drop Paper® 100	 Drop Paper® 101	 Drop Paper® 103
---	---	---

Matériaux
Material

Laiton massif Solid Brass	Abat-jour Drop Paper® M1 Lampshade Drop Paper® M1	Câble textile noir (longueur ≈ 2 m) Black textile cable (length ≈ 79")
------------------------------	--	---

Source
Lamping

Lampadaire – Floor lamp 1 x E27 205 W max. Ampoule non fournie 1 x E27 205 W max. Bulb not included	Variateur à pied Foot operated dimmer	Variation* Dimming*
1 x E26 type A 150 W. Bulb not included	Foot operated switch	
Lampe de table – Table lamp 1 x E27 105 W max. Ampoule non fournie 1 x E27 105 W max. Bulb not included	Interrupteur sur câble Cable switch	
1 x E26 type A 100 W. Bulb not included	Cable switch	

Designer

Hervé Langlais

* Les luminaires variables nécessitent l'utilisation d'ampoules compatibles avec la variation
All dimmable light fixture require the use of compatible bulbs



Ellis SB/PB

Lampadaire – Floor lamp

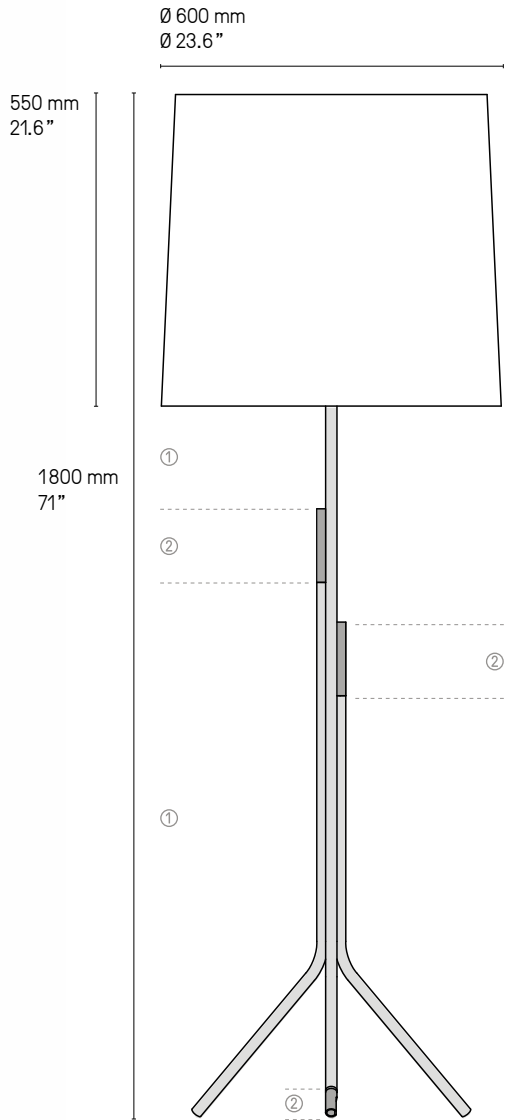

Lampe – Lamp

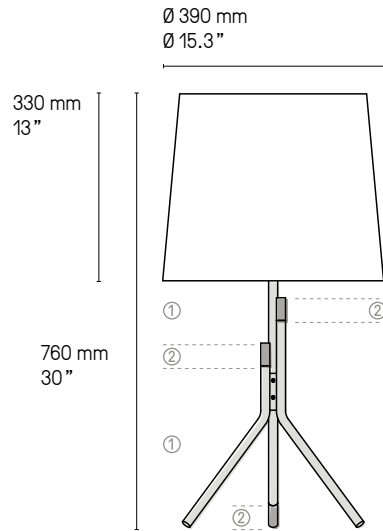











LINK

Sobre et minimaliste, la collection *Link* encadre la lumière. Selon l'orientation du luminaire, la ligne épurée s'inscrit dans l'espace vertical et horizontal.



Simple and minimalist, the *Link* collection frames the light. Depending on the position of the light, the refined line can be fitted vertically or horizontally.

Finitions Finishes

 Laiton satiné SB Satin brass	 Graphite satiné SG Satin graphite	 Nickel satiné SN Satin nickel	 Cuivre satiné SC Satin copper
 Laiton poli PB Polished brass	 Graphite poli PG Polished graphite	 Nickel poli PN Polished nickel	 Cuivre poli PC Polished copper

Matériaux Material

Laiton massif Solid Brass	Diffuseur polycarbonate satiné Satin Polycarbonate diff user	Lampadaire – Floor Lamp Câble textile noir (longueur ≈ 2 m) Black textile cable (length ≈ 79")
------------------------------	---	---

Source Lamping

Suspension – Pendant light

LED intégrée	1650 lm	2700° K	Alim. 24V int. dans le pavillon	Variable (phase cut)
Integrated LED	1650 lm	2700° K	Int. power supply incl. in canopy	Dimmable (phase cut)

Appliques – Wall lights



Link 985 (985 mm – 38.8")

LED intégrée	1080 lm	2700° K	Alim. électronique 24V intégrée	Variable (phase cut)
Integrated LED	1080 lm	2700° K	Int. power supply 24V included	Dimmable (phase cut)

Link 725 (725 mm – 28.5")

LED intégrée	780 lm	2700° K	Alim. électronique 24V intégrée	Variable (phase cut)
Integrated LED	780 lm	2700° K	Int. power supply 24V included	Dimmable (phase cut)

Link 525 (525 mm – 20.7")

LED intégrée	540 lm	2700° K	Alim. électronique 24V intégrée	Variable (phase cut)
Integrated LED	540 lm	2700° K	Int. power supply 24V included	Dimmable (phase cut)

Link 375 (375 mm – 14.8")

LED intégrée	360 lm	2700° K	Alim. électronique 24V intégrée	Variable (phase cut)
Integrated LED	360 lm	2700° K	Int. power supply 24V included	Dimmable (phase cut)

Link 275 (275 mm – 10.8")

LED intégrée	240 lm	2700° K	Alim. électronique 24V intégrée	Variable (phase cut)
Integrated LED	240 lm	2700° K	Int. power supply 24V included	Dimmable (phase cut)

Liseuses murales – Reading wall lights



Link 320 (320 mm – 12.7")

LED intégrée	120 lm	2700° K	Alimentation 24V intégrée	Variable (phase cut)
Integrated LED	120 lm	2700° K	Remote power supply 24V incl.	Dimmable (phase cut)

Link 410 (410 mm – 16.1")

LED intégrée	180 lm	2700° K	Alimentation 24V intégrée	Variable (phase cut)	Interrupteur intégré en option
Integrated LED	180 lm	2700° K	Int. power supply 24V included	Dimmable (phase cut)	Integrated switch: optional

Link 580 (580 mm – 22.8")

LED intégrée	360 lm	2700° K	Alimentation 24V intégrée	Variable (phase cut)	Interrupteur intégré en option
Integrated LED	360 lm	2700° K	Int. power supply 24V included	Dimmable (phase cut)	Integrated switch: optional

Link double 610 (610 mm – 24.1")

LED intégrée	360 lm	2700° K	Alimentation 24V intégrée	Variable (phase cut)
Integrated LED	360 lm	2700° K	Int. power supply 24V included	Dimmable (phase cut)

Link double 960 (960 mm – 37.8")

LED intégrée	720 lm	2700° K	Alimentation 24V intégrée	Variable (phase cut)
Integrated LED	720 lm	2700° K	Int. power supply 24V included	Dimmable (phase cut)

Link double 1300 (1300 mm – 51.2")

LED intégrée	960 lm	2700° K	Alimentation 24V intégrée	Variable (phase cut)	2 interrupteurs int. en option
Integrated LED	960 lm	2700° K	Int. power supply 24V included	Dimmable (phase cut)	2 int. switches: optional

Lampadaire – Floor lamp

LED intégrée	1200 lm	2700° K	Alimentation intégrée sur la prise	Interrupteur à pied
Integrated LED	1200 lm	2700° K	Plug-in power supply	Foot operated switch

Lampe de table – Table lamp

LED intégrée	300 lm	2700° K	Alimentation intégrée sur la prise	Interrupteur sur câble
Integrated LED	300 lm	2700° K	Plug-in power supply	Cable switch

Appliques – Wall lights

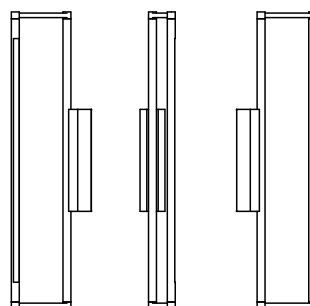
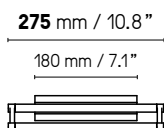
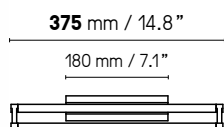
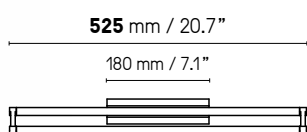
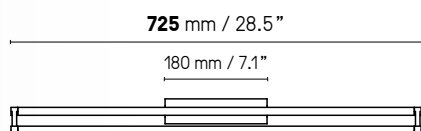
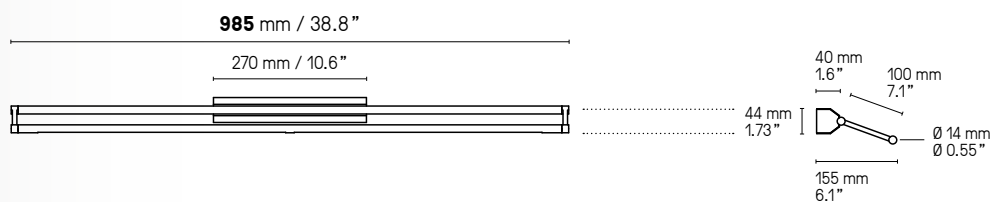

Link peut être installée horizontalement ou verticalement.
Link can be placed both horizontally or vertically on the wall.

Longueurs sur mesure possibles.
 Custom dimensions available upon request.

UL Version
 fitted plate to cover outlet power box

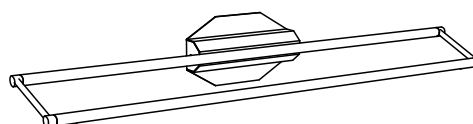
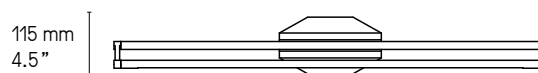

Description Features

Cette applique est réglable sur 2 axes. Le tube avant, dans lequel se trouve la LED tourne afin de diriger la lumière dans n'importe quelle direction. L'ensemble formant un cadre peut également pivoter de haut en bas si l'applique est installée à l'horizontale, ou de gauche à droite si elle est installée à la verticale.

The wall light is adjustable in 2 ways. The front LED bar can be spinned around to diffuse the light in any direction and the rectangular frame can be flipped up and down when the light is positioned horizontally, and side to side when positioned vertically.



Liseuses murales – Reading wall lights

Longueurs sur mesure possibles.
Custom dimensions available upon request.

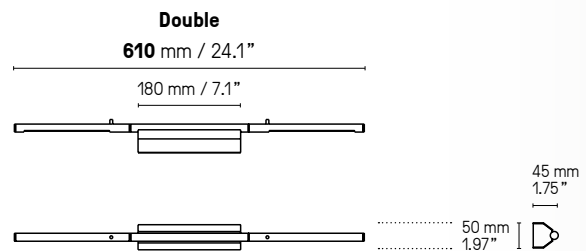
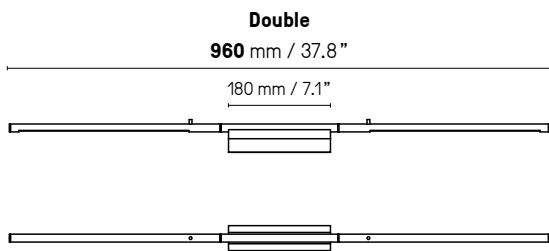
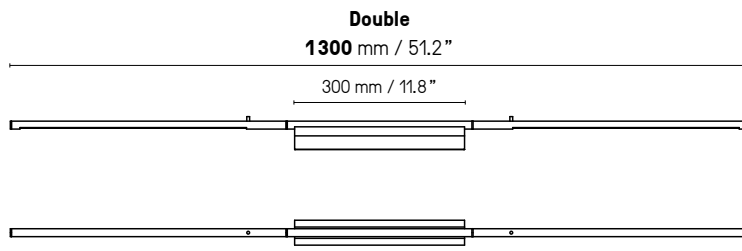
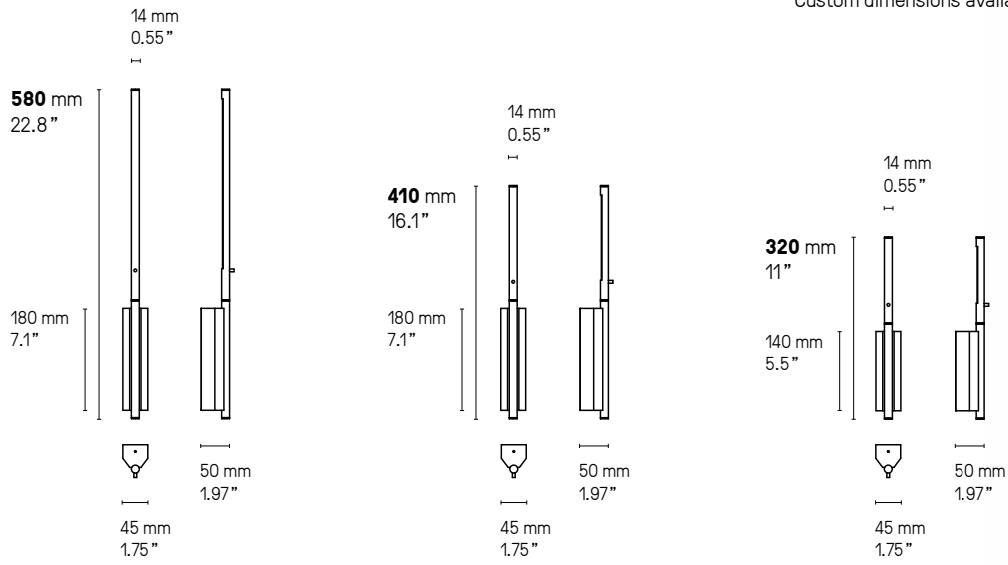

**UL Version
fitted plate
to cover outlet
power box**

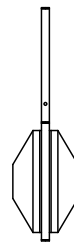

115 mm
4.5"

Lampadaire – Floor lamp

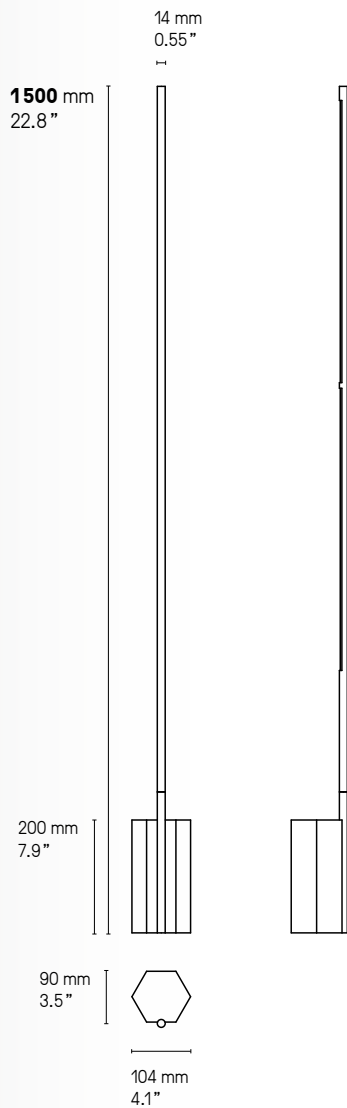

Lampadaire – Floor lamp Link SB

Lampe de table – Table lamp

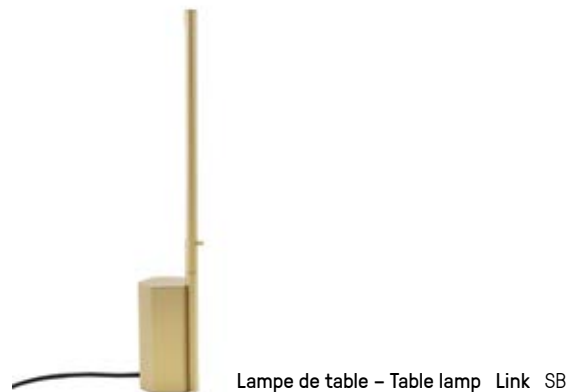
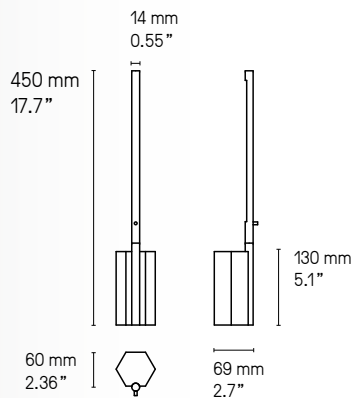

Lampe de table – Table lamp Link SB





Suspension – Pendant

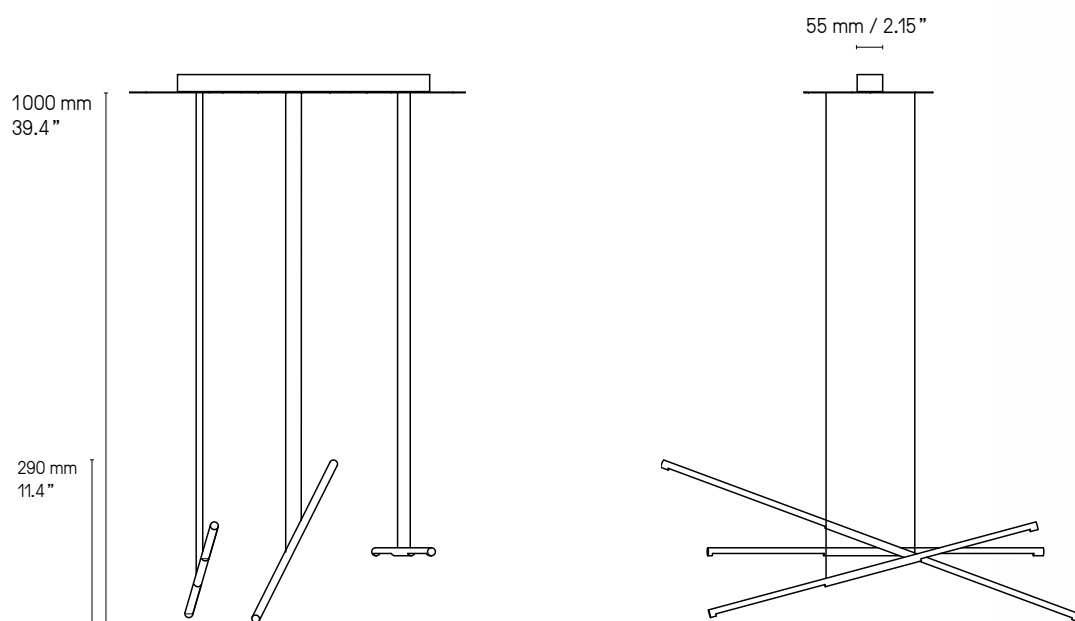
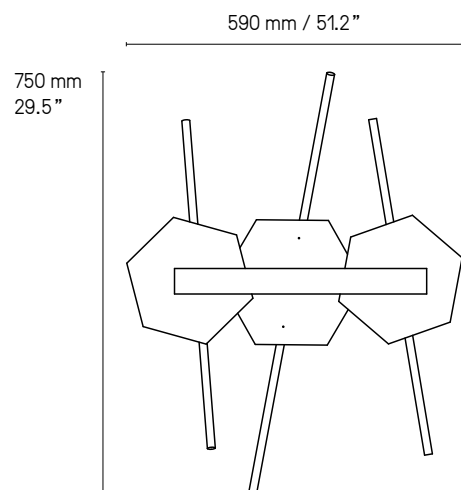

La longueur des câbles est réglable à l'installation.
The height of the cables can be adjusted during installation.



Suspensions – Pendant Link SB





Liseuse – Reading light Link 410 SB



LOUIS & FLEA

Collection inspirée par le célèbre artiste de jazz, les suspensions *Louis* et les appliques *Fléa* jouent des effets de lumières avec le verre et le laiton. Modulables, créez vos compositions de « trompettes » à l'envi.



A collection inspired by the iconic jazz artist, the *Louis* pendants and *Fléa* wall lights play with lighting effects on the glass and the brass. Adjustable, you can arrange the “trumpets” as you wish.

LOUIS

Finitions Finishes

● Laiton satiné
SB Satin brass

● Graphite satiné
SG Satin graphite

● Nickel satiné
SN Satin nickel

● Cuivre satiné
SC Satin copper

Nuances du verre Glass colors

● Opale
Opal

● Opale et écaille
Opal and patterned

● Claire et écaille
Clear and patterned

Câble Cable

■ Tissu noir
Black textile

■ Tissu or
Gold textile

*La longueur standard des câbles est de 2 mètres mais elle peut être diminuée à l'installation.
The standard height of the cables is 2 meters (79") but can be adjusted to less during installation.*

Matériaux Material

Laiton massif
Solid Brass

Verrerie soufflée bouche
Mouth-blown glass

Câble textile
Textile cable

Source Lamping

LED intégrée 1500 lm 2700°K
Integrated LED 1500 lm 2700°K

Alim. électr. intégrée dans le pavillon
Int. power supply included in canopy

Variation. Veuillez nous contacter
Dimming. Please, contact us



Designer

Émilie Cathelineau

Louis XS

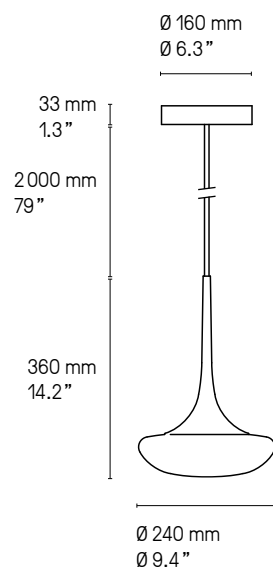

Louis XL

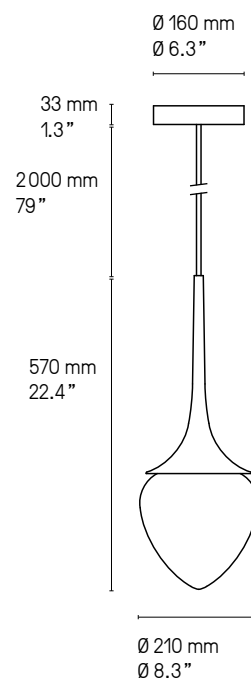

500 mm
19.7"

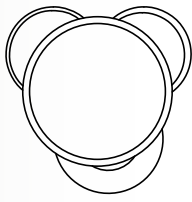

580 mm
22.8"

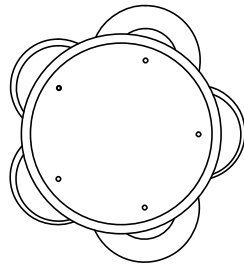

1100 mm
43.3"

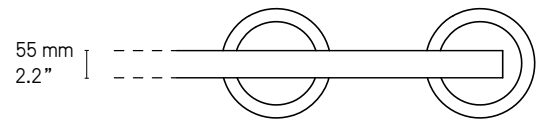

Ø 340 mm / 13.4"
Ø 300 mm / 11.8"

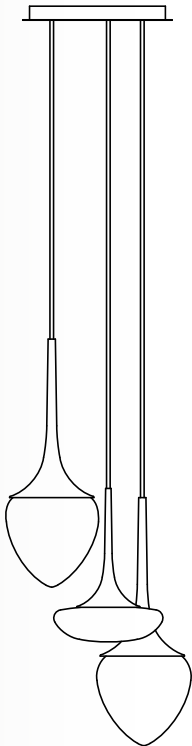

Ø 440 mm / 17.3"
Ø 400 mm / 15.7"

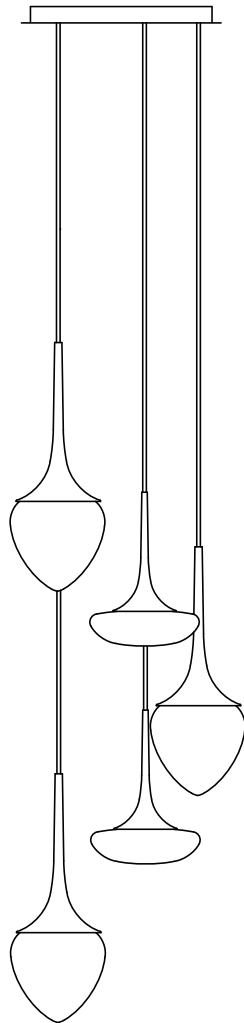

1000 mm / 39.4"

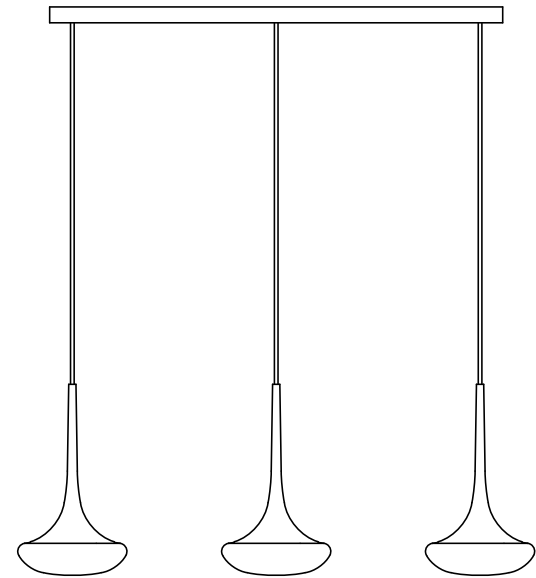

Il est possible de rassembler plusieurs suspensions sur un seul pavillon, circulaire ou rectangulaire. La version rectangulaire peut être adaptée à n'importe quelle longueur. La version circulaire a un diamètre maximum indiqué sur les croquis ci-dessus. Pour plus de renseignements, veuillez nous contacter.



It is possible to cluster several pendants from one single canopy, either rectangular or circular. The rectangular canopy can be custom-made into any size to suit your requirements. As for the circular canopy, available sizes are illustrated above. Please contact us for further information.





FLÉA

Finitions Finishes	 Laiton satiné	 Graphite satiné	 Nickel satiné	 Cuivre satiné
	SB Satin brass	SG Satin graphite	SN Satin nickel	SC Satin copper

Câble Cable	 Tissu noir	 Tissu or	<p><i>La longueur standard des câbles est de 2 mètres pour les suspensions et 15 cm pour les appliques mais elle peut être diminuée à l'installation. Autres longueurs sur demande.</i></p> <p><i>The standard height of the cables is 2 meters (79") for a pendant and 150 mm (5,9") for a wall light it can be adjusted to to less during installation. Custom heights available upon request.</i></p>
	Black textile	Gold textile	

Matériaux Material	Laiton massif	Verre pressé	Câble textile
	Solid Brass	Pressed clear glass	Textile cable

Source Lamping	G9 LED 5W max. non fournie		Variation*
	G9 LED 5W max. not included	Not available for 110V	Dimming*

Designer	Émilie Cathelineau
-----------------	--------------------

* Les luminaires variables nécessitent l'utilisation d'ampoules compatibles avec la variation
All dimmable light fixture require the use of compatible bulbs

Applique – Wall light

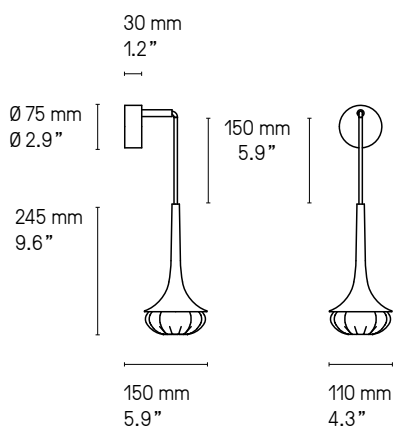

Applique – Wall light Flea SB

Suspension – Pendant

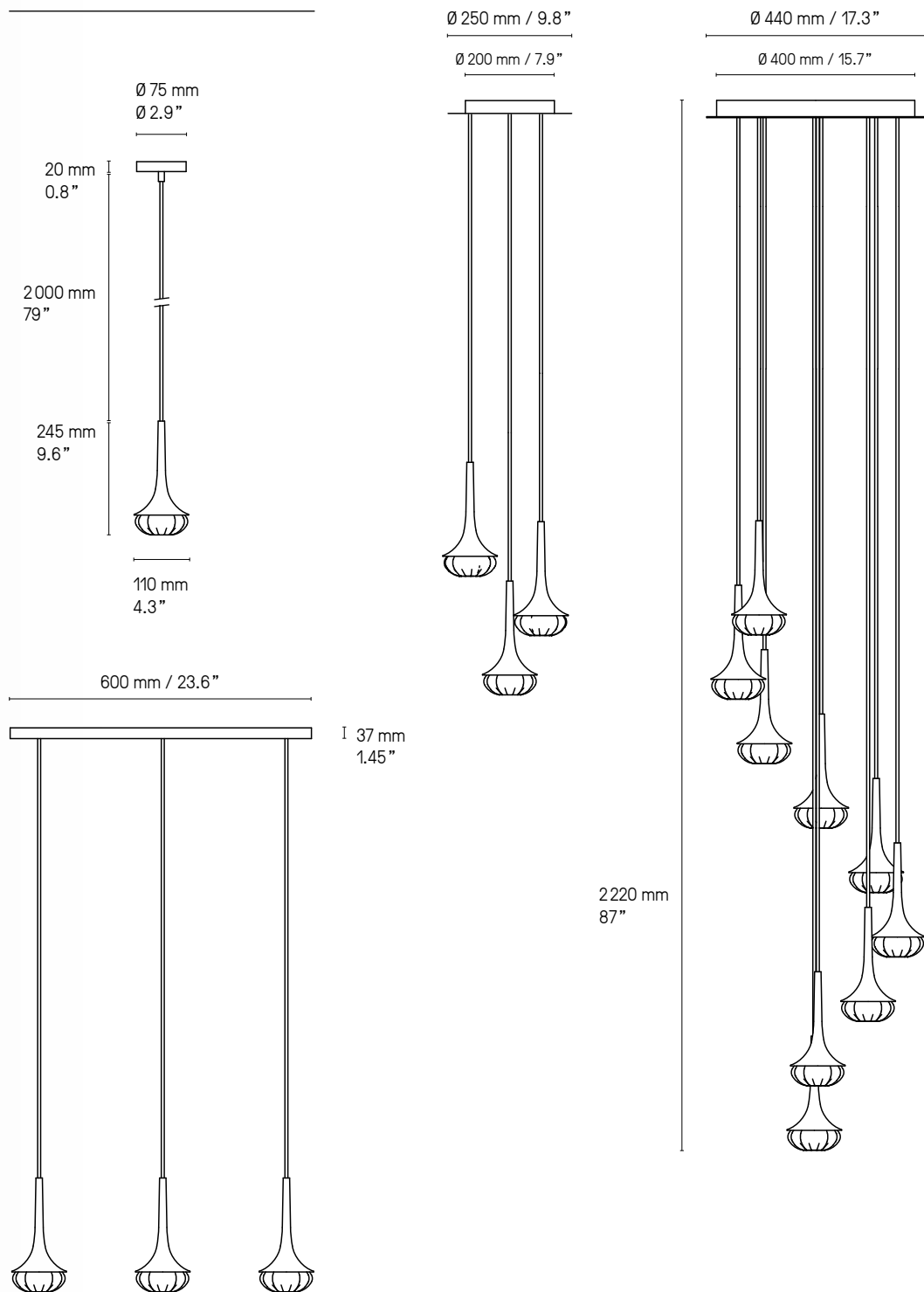

Il est possible de rassembler plusieurs suspensions sur un seul pavillon, circulaire ou rectangulaire. La version rectangulaire peut être adaptée à n'importe quelle longueur. La version circulaire a un diamètre maximum indiqué sur les croquis ci-dessus. Pour plus de renseignements, veuillez nous contacter.

It is possible to cluster several pendants from one single canopy, either rectangular or circular. The rectangular canopy can be custom-made into any size to suit your requirements. As for the circular canopy, available sizes are illustrated above. Please contact us for further information.



QUATORZE JUILLET

La guirlande, symbole de fêtes, se transforme avec *Quatorze juillet* en luminaire aussi précieux qu'épuré. Une véritable révolution à la française.



The garland, symbolic of celebrations, transforms the *Quatorze juillet* into a fairy light which is as precious as it is refined. A true French-style revolution.

**Finitions
Finishes**

● Laiton satiné
SB Satin brass

● Graphite satiné
SG Satin graphite

● Nickel satiné
SN Satin nickel

● Cuivre satiné
SC Satin copper

**Matériaux
Material**

Laiton massif
Solid Brass

Verre
Glass

**Description
Features**

Existe en 2 tailles (XS et XL) aussi bien en suspension qu'en applique.
La taille XS possède 5 verreries Ø70 mm et a une longueur maximum de 1,6 m.
La taille XL possède 5 verreries Ø90 mm et a une longueur maximum de 2 m.
La longueur et la hauteur dépendent de l'entraxe des fixations.

Comes as a pendant or a wall mounted light both in 2 different sizes (XS and XL).
The XS size has 5 glass bulbs with a diameter of 70 mm (2.7") and has a maximum length of 1,6m (63").
The XL size has 5 glass bulbs with a diameter of 90 mm (3.5") and has a maximum length of 2m (79").
The length and height depend on how the light is fixed.
14 juillet is not available for 110V.

**Source
Lamping**

G9 LED 5 x 5W max non incluses
G9 LED 5 x 5W max not included

Not available for 110V

Variation*
Dimming*

Designer

Kristian Gavaille

* Les luminaires variables nécessitent l'utilisation d'ampoules compatibles avec la variation
All dimmable light fixture require the use of compatible bulbs



Applique – Wall light Quatorze juillet SB

Applique – Wall light XL

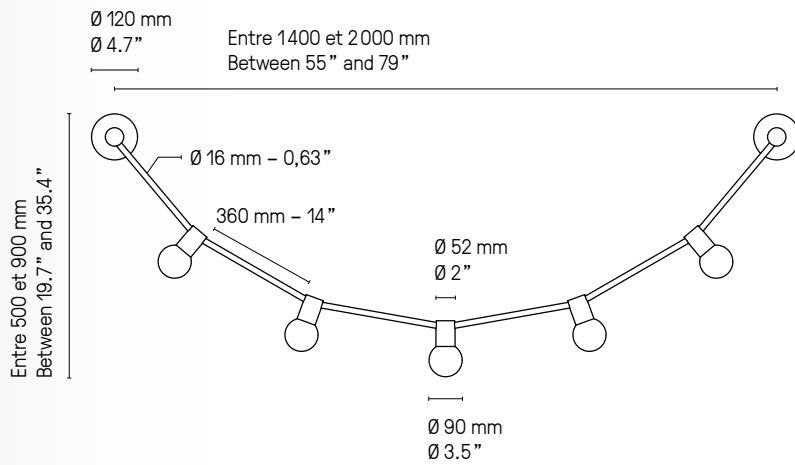

Suspension – Pendant XL

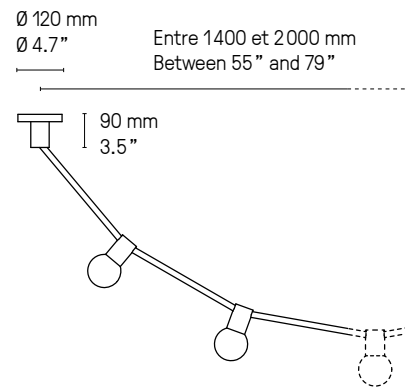

Applique – Wall light XS

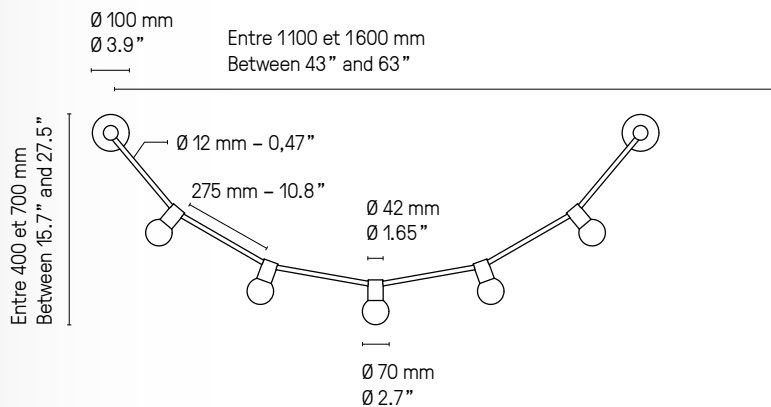

Suspension – Pendant XS

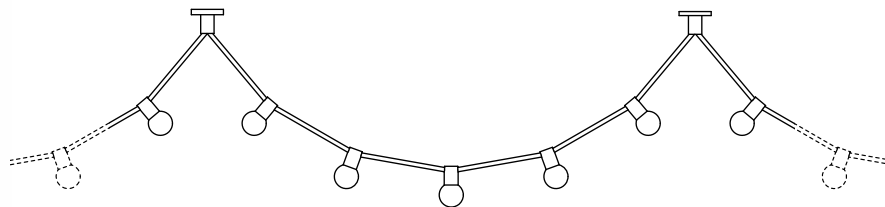
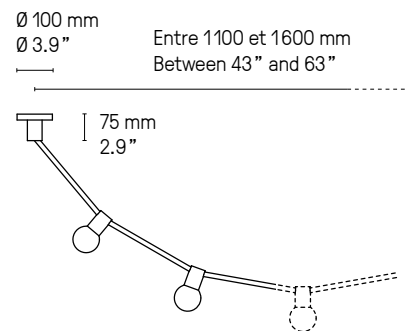

Il est possible de connecter plusieurs *Quatorze juillet* avec une seule sortie électrique. Veuillez nous contacter.

It is possible to have another cable come out of the mounting plate if you choose to extend the light by adding another cable or more.



RING

À la fois inspirée des années 60 et intemporelle, la suspension bicolore *Ring* est montée d'une pièce « bijou » en laiton poli. Définissez ses tonalités selon l'effet décoratif recherché.





At once inspired by the 60's but also timeless, the two-toned pendant *Ring* is assembled with an imitated polished brass "jewel". Characterize its shades in accordance to the style you are looking for.

**Finitions
Finishes****Bicolore – Bicolor** ① / ②

 Graphite satiné
SG / Laiton satiné
SB Satin graphite
/ Satin brass

 Laiton satiné
SB / Graphite satiné
SG Satin brass
/ Satin graphite

 Graphite satiné
SG / Nickel satiné
SN Satin graphite
/ Satin nickel

 Nickel satiné
SN / Graphite satiné
SG Satin nickel
/ Satin graphite

**Finitions
Finishes****Uni – Unicolor**

 Laiton satiné
SB Satin brass

 Graphite satiné
SG Satin graphite

 Nickel satiné
SN Satin nickel

 Cuivre satiné
SC Satin copper

**Matériaux
Material**

Laiton massif
Solid Brass

Diffuseur en polycarbonate
Polycarbonate diffuser

**Description
Features**

Le modèle standard n'a pas de câble. Il est fixe sur un tube de 300 mm de long, ce qui donne une hauteur totale de 440 mm. Si vous souhaitez une hauteur supérieure à 440 mm, il est possible de réaliser une version « sur câble ». La longueur standard des câbles est de 2 mètres mais elle peut être diminuée à l'installation.

The standard *Ring* light does not come with a cable but only with a 300mm (11,8") brass stem with a total drop of 440mm (17,3"). For lengths over 440mm (17,3") an adjustable transparent cable is added between the brass stem and the canopy in a standard length of 2 meters (79") and can be adjusted to less during installation.

**Source
Lamping**

2 modules de LEDS intégrées : 2 x 1700lm / 2700°K
Diffusion de la lumière directe et indirecte

Alim. électronique intégrée dans le pavillon
Variation. Veuillez nous contacter

2 integrated LEDs of 1700lm / 2700°K
Diffuses light from the top and the bottom

Integrated power supply in canopy
Dimming. Please, contact us



Designer

Émilie Cathelineau

Version fixe – Stem version

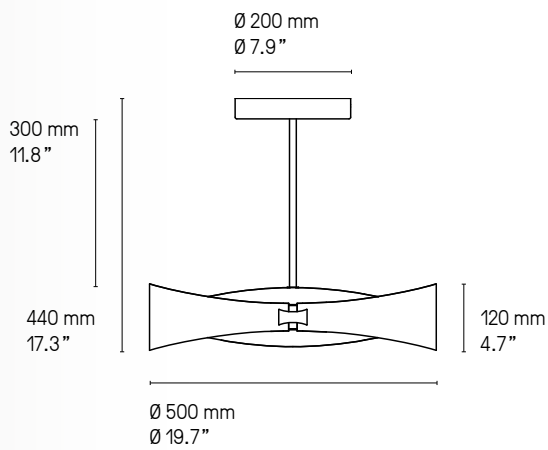

Version câble – Cable version

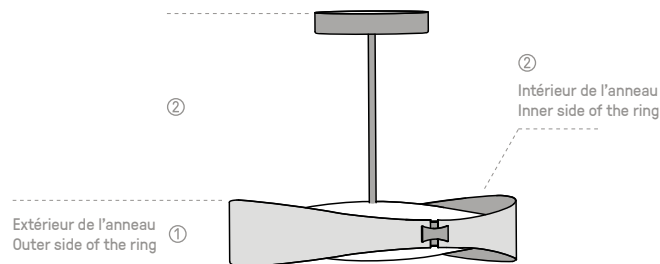
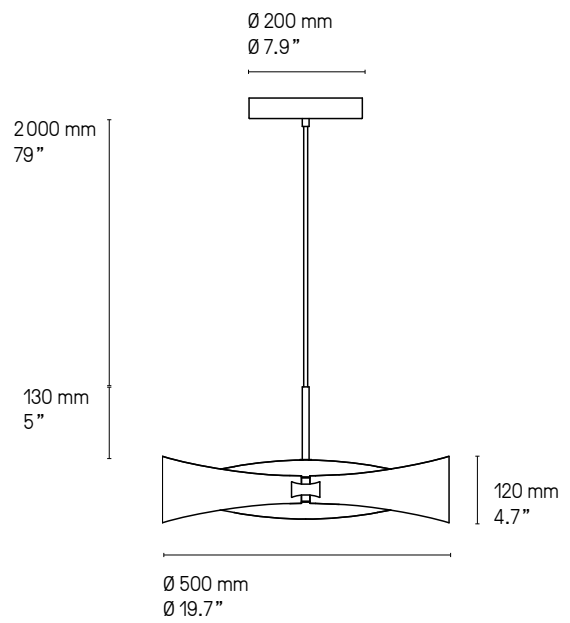

En standard, les 2 « bijoux » sur le côté du produit sont en finition ② polie. Si vous préférez une finition satinée, merci de le préciser.

The 2 small brass parts on each side of the light always come in a polished ② finish but can be in satin if specified.



SATURNE

La sphère lumineuse est ici prétexte au voyage dans le système solaire. Munie d'un anneau en laiton orientable, la suspension *Saturne* devient le reflet de votre vision du cosmos.



For this particular light, the luminous sphere is a representation of the solar system. Provided with a rotating brass ring, the *Saturne* pendant becomes your vision of the cosmos.

Finitions
Finishes

● Laiton satiné SB Satin brass	● Graphite satiné SG Satin graphite	● Nickel satiné SN Satin nickel	● Cuivre satiné SC Satin copper
---	--	--	--

Matériaux
Material

Laiton massif Solid Brass	Verrerie opale soufflée bouche Opal mouth-blown glass	Câble textile Textile cable
------------------------------	--	--------------------------------

Câble
Cable

■ Tissu noir Black textile	■ Tissu or Gold textile
--	--

*La longueur standard des câbles est de 2 mètres mais elle peut être diminuée à l'installation.
The standard height of the cables is 2 meters (79") but can be adjusted to less during installation.*

Source
Lamping

XL	LED intégrée Integrated LED	1300 lm 1300 lm	2700°K 2700°K	Alimentation int. dans le pavillon Int. power supply incl. in canopy	Variation. Veuillez nous contacter Dimming. Please, contact us
XS	LED intégrée Integrated LED	800 lm 800 lm	2700°K 2700°K	Alimentation int. dans le pavillon Int. power supply incl. in canopy	Variation. Veuillez nous contacter Dimming. Please, contact us



Designer

Hervé Langlais

Saturne XL

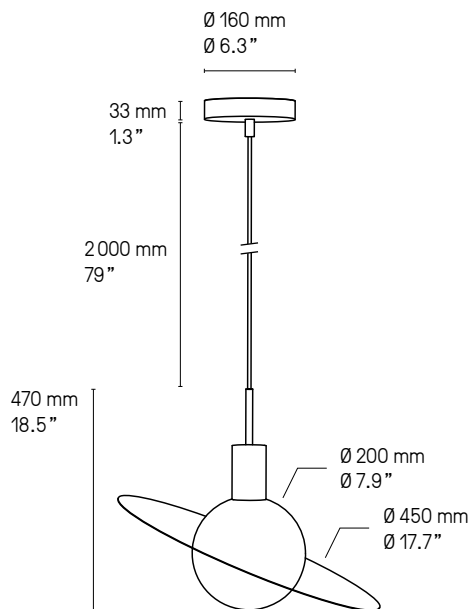

Saturne XS

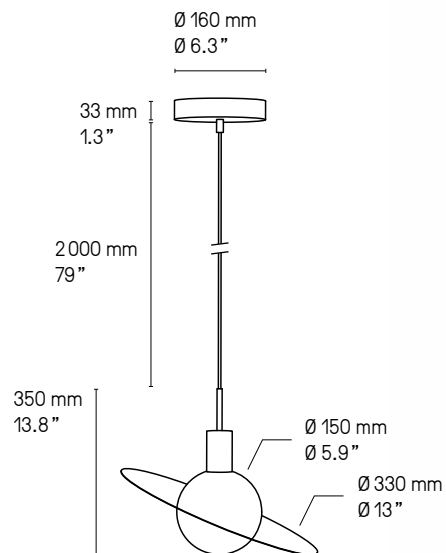

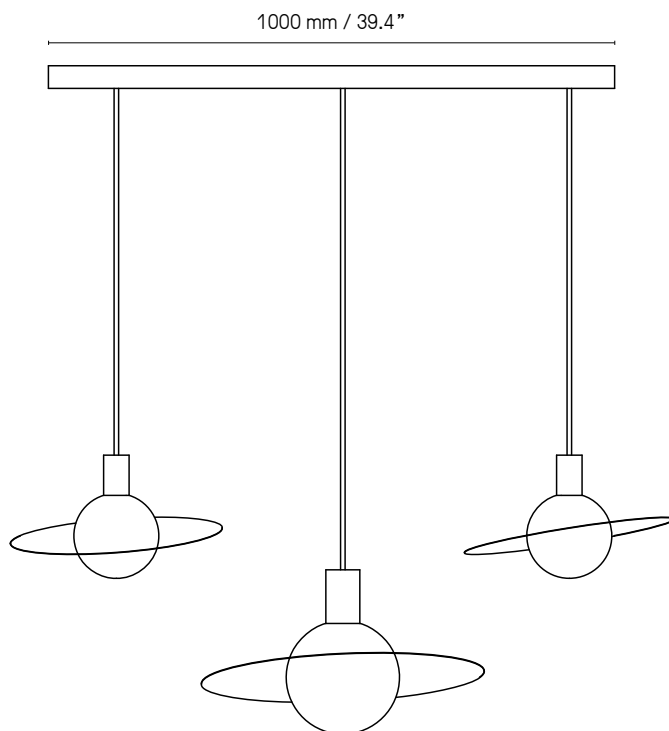
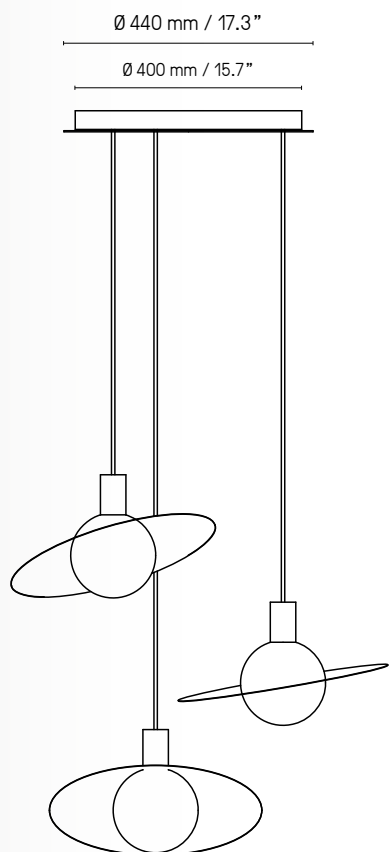

Il est possible de rassembler plusieurs suspensions sur un seul pavillon, circulaire ou rectangulaire. La version rectangulaire peut être adaptée à n'importe quelle longueur. La version circulaire a un diamètre maximum indiqué sur les croquis ci-dessus. Pour plus de renseignements, veuillez nous contacter.

It is possible to cluster several pendants from one single canopy, either rectangular or circular. The rectangular canopy can be custom-made into any size to suit your requirements. As for the circular canopy, available sizes are illustrated above. Please contact us for further information.











SIGNAL

Apporter des lettres de noblesse au néon d'antan, voici l'esprit de la collection *Signal*. Véritable clin d'œil élégant, l'originalité de la source lumineuse désaxée se décline en appliques et suspensions.



Bringing something ancient back to fashion, this is what Pauline had in mind for the *Signal* collection. An elegant allusion, declined in wall lights and pendants, with their original asymmetric light source.

Finitions Finishes

 Laiton satiné SB Satin brass	 Graphite satiné SG Satin graphite	 Nickel satiné SN Satin nickel	 Cuivre satiné SC Satin copper
 Laiton poli PB Polished brass	 Graphite poli PG Polished graphite	 Nickel poli PN Polished nickel	 Cuivre poli PC Polished copper

Matériaux Material

Laiton massif Solid Brass	Diffuseur polycarbonate blanc White Polycarbonate diffuser	Signal x 3, Chandelier, V540, V440, V340 Câble textile noir (longueur ≈ 2 m) Black textile cable (length ≈ 79")
------------------------------	---	--

Signal H970, H770
Câble métallique gainé (longueur ≈ 2 m)
Sheathed metal cable (length ≈ 79")

*La longueur peut être diminuée à l'installation.
The height can be adjusted to less during installation.*

Source Lamping

Suspensions – Pendants

Chandelier Signal

LED intégrée	2880 lm	2700°K	Alim. 24 V int. dans le pavillon	Variable (phase cut)
Integrated LED	2880 lm	2700°K	Int. power supply 24V incl. in canopy	Dimmable (phase cut)

Signal x 3

LED intégrée	2160 lm	2700°K	Alim. 24 V int. dans le pavillon	Variable (phase cut)
Integrated LED	2160 lm	2700°K	Int. power supply 24V incl. in canopy	Dimmable (phase cut)

Signal H970

LED intégrée	1680 lm	2700°K	Alim. 24 V int. dans le pavillon	Variable (phase cut)
Integrated LED	1680 lm	2700°K	Int. power supply 24V incl. in canopy	Dimmable (phase cut)

Signal H770

LED intégrée	1200 lm	2700°K	Alim. 24 V int. dans le pavillon	Variable (phase cut)
Integrated LED	1200 lm	2700°K	Int. power supply 24V incl. in canopy	Dimmable (phase cut)

Signal V540

LED intégrée	960 lm	2700°K	Alim. 24 V int. dans le pavillon	Variable (phase cut)
Integrated LED	960 lm	2700°K	Int. power supply 24V incl. in canopy	Dimmable (phase cut)

Signal V440

LED intégrée	720 lm	2700°K	Alim. 24 V int. dans le pavillon	Variable (phase cut)
Integrated LED	720 lm	2700°K	Int. power supply 24V incl. in canopy	Dimmable (phase cut)

Signal V340

LED intégrée	480 lm	2700°K	Alim. 24 V int. dans le pavillon	Variable (phase cut)
Integrated LED	480 lm	2700°K	Int. power supply 24V incl. in canopy	Dimmable (phase cut)

Applique – Wall light

LED intégrée	240 lm	2700°K	Alimentation 24 V intégrée
Integrated LED	240 lm	2700°K	Int. power supply 24 V included

Designer

Pauline Deltour

Signal Chandelier

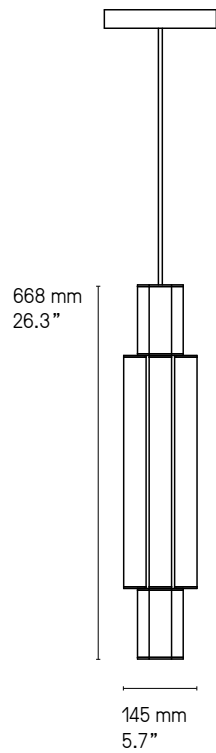
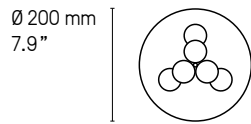

Signal x 3

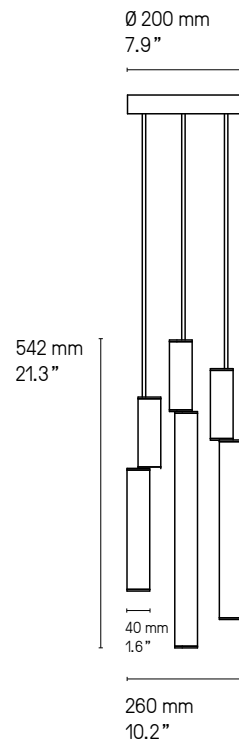
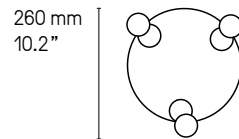

Signal H 970

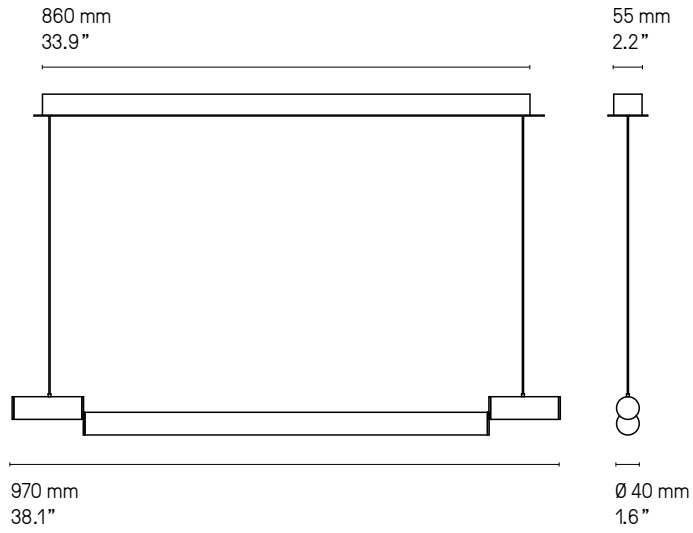

Signal H 770

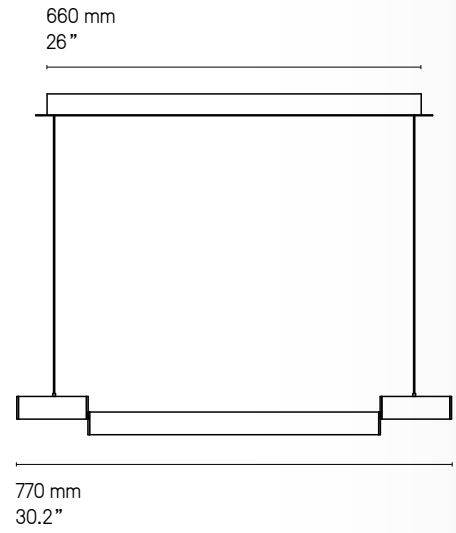

Signal V 540

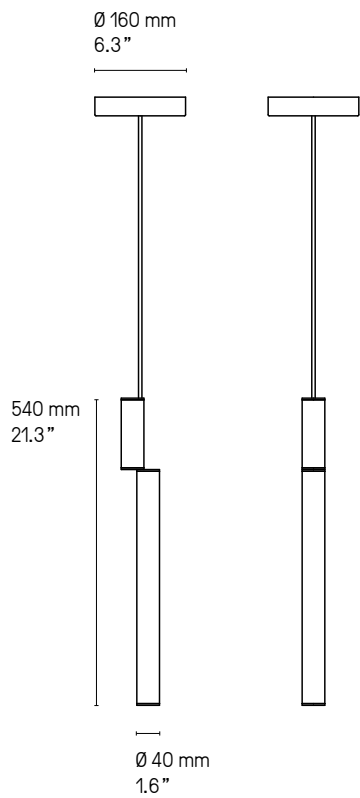

Signal V 440

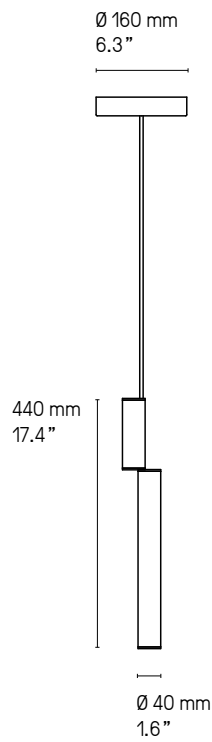

Signal V 340

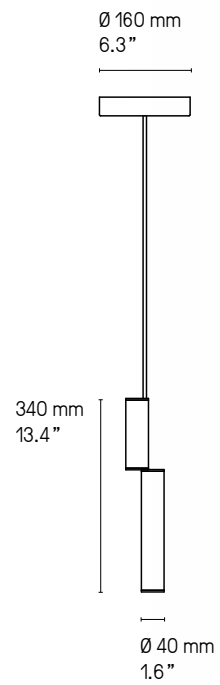

Applique – Wall light

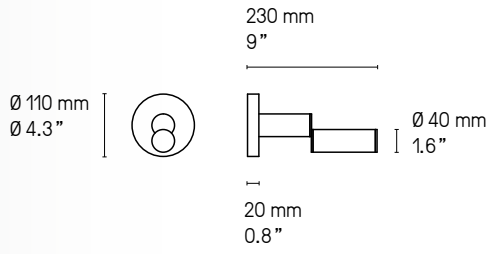

Applique – Wall light Signal SB



Suspension – Pendant Signal V540 SB



Suspension – Pendant Signal x3 SG















SOLITAIRE

Ce lampadaire trépied, rehaussé d'un abat-jour à facettes, courtise le bicolore. Personnalisable à souhait, cette pièce unique s'approprie avec élégance vos choix de finitions.





This three-legged floor lamp, enhanced by a faceted lampshade, is even more flattering in a two-tone finish. This unique piece, which can be customized, elegantly blends together with your choice of finishes.

Finitions
Finishes ①+②

 Laiton satiné SB Satin brass	 Graphite satiné SG Satin graphite	 Nickel satiné SN Satin nickel	 Cuivre satiné SC Satin copper
 Laiton poli PB Polished brass	 Graphite poli PG Polished graphite	 Nickel poli PN Polished nickel	 Cuivre poli PC Polished copper

Abat-jour
Lampshade

 Chinette noire Black chinette	 Chinette blanche White chinette
--	--

Matériaux
Material

Laiton massif Solid Brass	Abat-jour tissu Textile lampshade	Câble textile noir (longueur ≈ 1.5 m) Black textile cable (length ≈ 59")
------------------------------	--------------------------------------	---

Source
Lamping

1 x E27 205 W max. Ampoule non fournie 1 x E27 205 W max. Bulb not included	Variateur à pied Foot operated dimmer	Variation* Dimming*
1 x E26 type A 150W. Bulb not included	Foot operated switch	



Designer

Émilie Cathelineau

* Les luminaires variables nécessitent l'utilisation d'ampoules compatibles avec la variation
All dimmable light fixture require the use of compatible bulbs

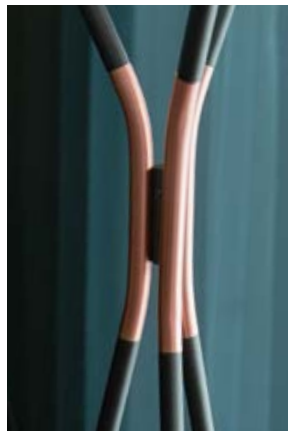

Solitaire XS SB/PB

Solitaire XL SG/SC



Solitaire XL

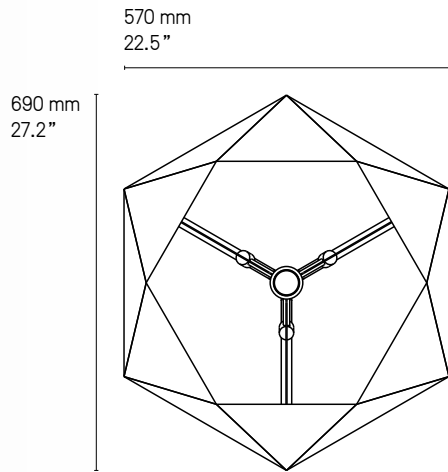

Solitaire XS

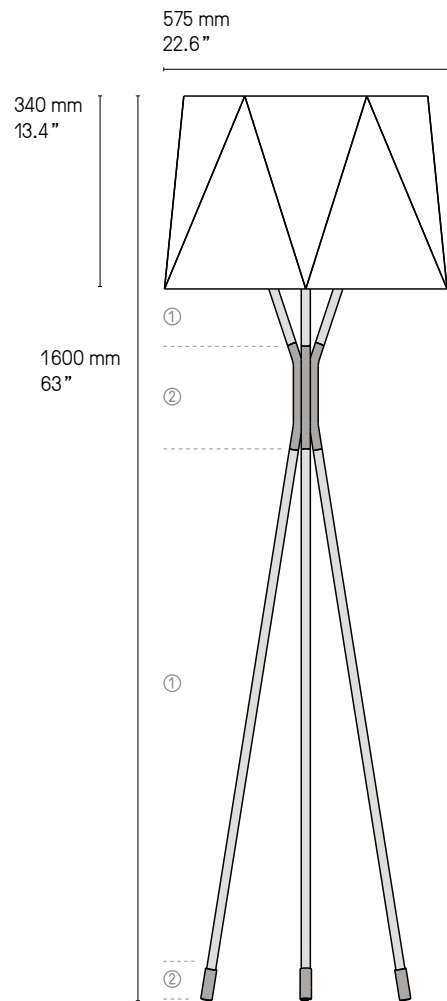
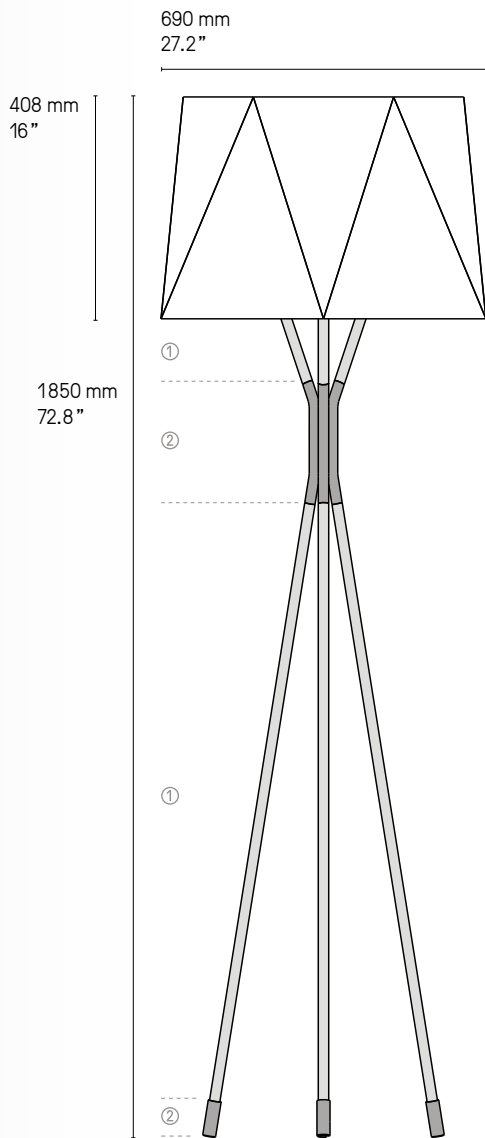
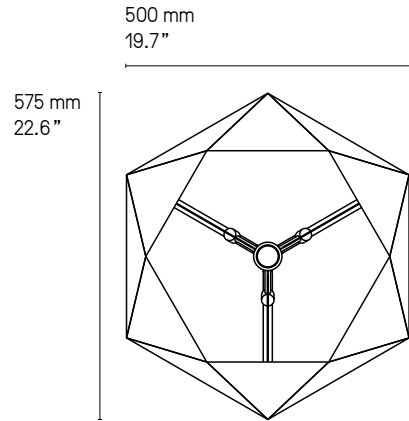











STORM

Lumière dirigée pour cette réinterprétation de la lampe tempête. La suspension et la lampe *Storm* affichent des lignes épurées, en toute intimité.



A reinterpretation of a storm made by light. The *Storm* pendant and lamp show off delicate and refined lines.

**Finitions
Finishes**

 Laiton satiné SB Satin brass	 Graphite satiné SG Satin graphite	 Nickel satiné SN Satin nickel	 Cuivre satiné SC Satin copper
 Laiton poli PB Polished brass	 Graphite poli PG Polished graphite	 Nickel poli PN Polished nickel	 Cuivre poli PC Polished copper

**Matériaux
Material**

Tous – All
Laiton massif
Solid Brass

Lampe de table – Table lamp *Storm* diffuser
Diffuseur polycarbonate blanc
White Polycarbonate diffuser

Suspension – Pendant
Câble métallique gainé
*La longueur standard des câbles est de 2 mètres
mais elle peut être diminuée à l'installation.*
Sheathed metal cable.
*The standard height of the cables is 2 meters
(79") but can be adjusted to less during installation.*

**Source
Lamping**

Lampe de table – Table lamp *Storm*
LED 600 lm 2700°K

Alim. intégrée sur la prise
Plug-in power supply

Lampe de table – Table lamp *Storm* diffuser
LED 480 lm 2700°K

Alim. intégrée sur la prise
Plug-in power supply

Suspension – Pendant
LED 600 lm 2700°K

Alimentation intégrée dans le pavillon
Int. power supply included in canopy

Variable (phase cut)
Dimmable (phase cut)

Designer

Émilie Cathelineau



Lampe de table – Table lamp Storm

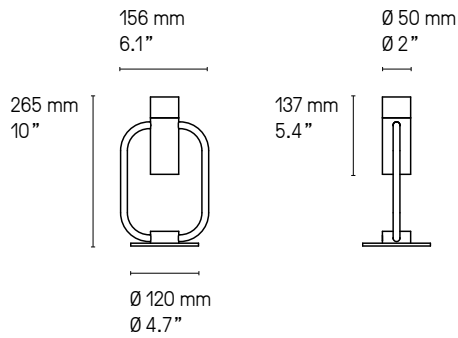

Lampe de table – Table lamp Storm SB

Lampe de table – Table lamp Storm diffuser

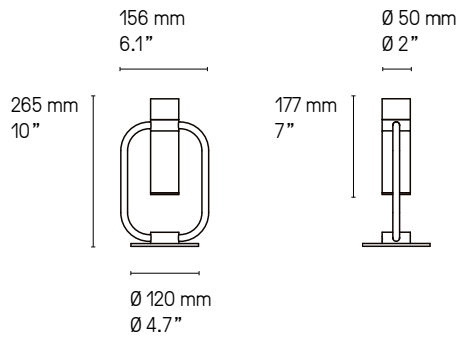

Lampe de table – Table lamp Storm glass SG

Lampe de Bureau – Desk table lamp Storm XL

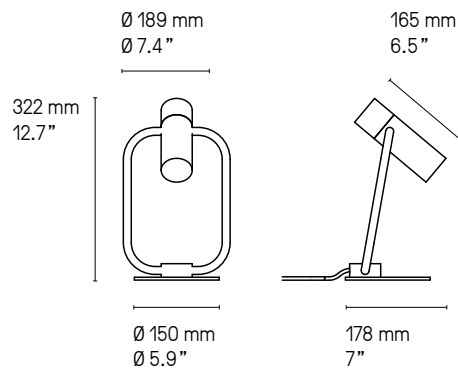

Lampe de Bureau – Desk lamp Storm Desk XL SN

Applique – Wall light *Storm diffuser*

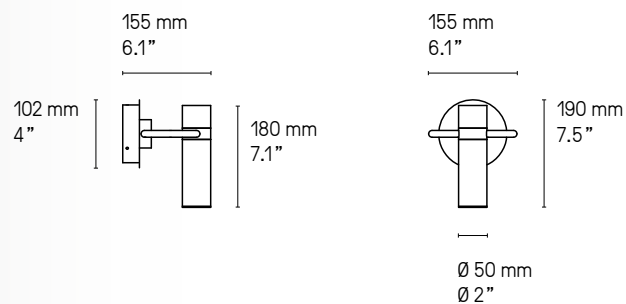

Applique – Wall light Storm SB

Lampadaire – Floor lamp *Storm diffuser*

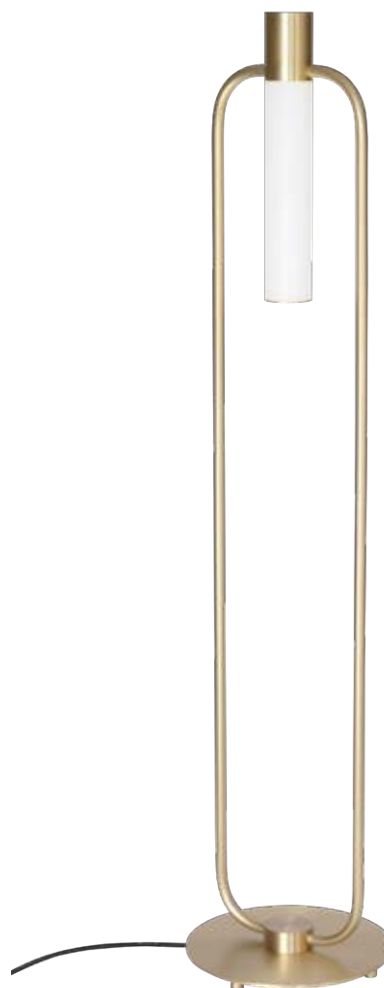
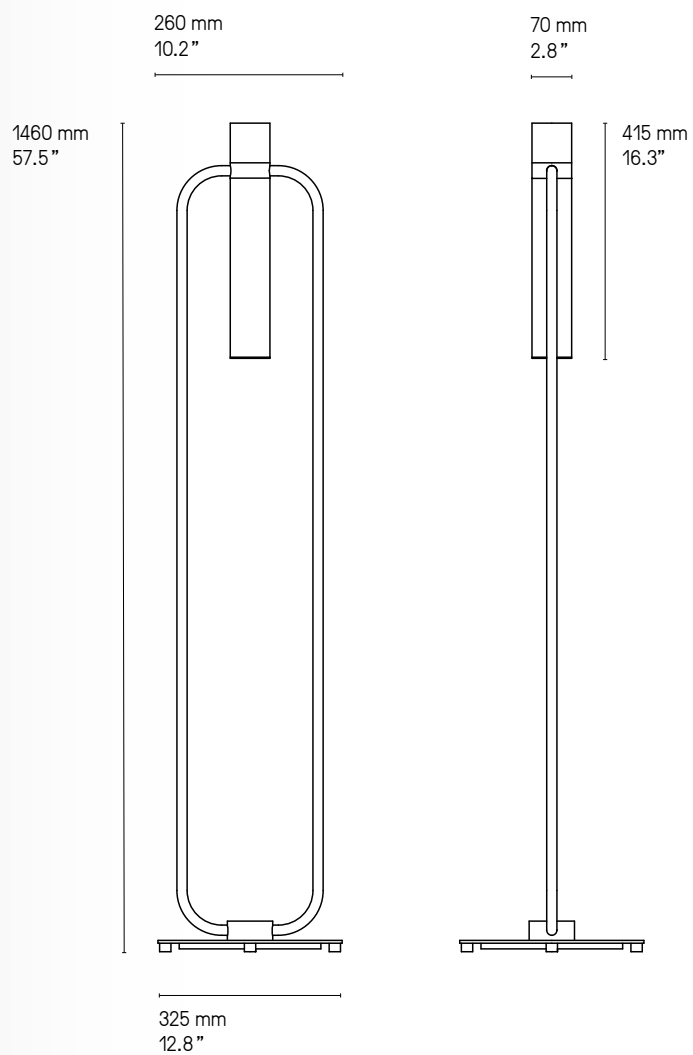

Lampadaire – Floor lamp Storm SB

Suspension - Pendant

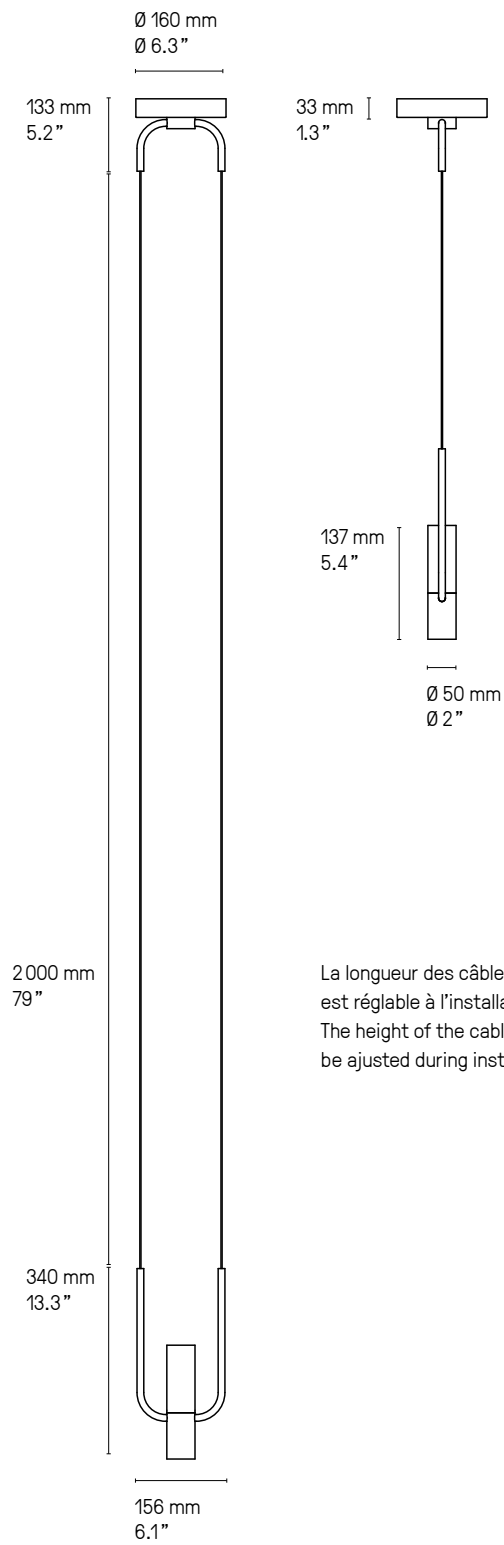

La longueur des câbles est réglable à l'installation.
The height of the cables can be adjusted during installation.



Suspension – Pendant Storm SG

Suspension – Pendant Storm SB













TÉTRA

Seul ou en composition, le module triangulaire *Tétra* dessine par la lumière vos inspirations. Un objet sobre se multipliant à l'infini.



By itself or as an arrangement, the triangular module *Tétra* can shape your own creation with light. A simple object that can be multiplied endlessly.

Finitions
Finishes

 Laiton satiné SB Satin brass	 Graphite satiné SG Satin graphite	 Nickel satiné SN Satin nickel	 Cuivre satiné SC Satin copper
 Laiton poli PB Polished brass	 Graphite poli PG Polished graphite	 Nickel poli PN Polished nickel	 Cuivre poli PC Polished copper

Matériaux
Material

Laiton massif Solid Brass	Diffuseur en polycarbonate Polycarbonate diff user
------------------------------	---

Description
Features

Lorsqu'ils sont positionnés côte à côte, les luminaires Tétra peuvent être interconnectés grâce à un câble circulant entre le mur et l'arrière du luminaire. Ce montage ne nécessite qu'une seule sortie électrique. Veuillez noter que le système d'interconnexion n'est pas certifié UL.

Positioned side by side, Tetra lights can be interconnected with a cable that runs between the wall and the back of the lights. This arrangement requires only one electrical outlet. Please be aware that this interconnected system is not up to code in the US and is not UL certified.

Source
Lamping

LED intégrée Integrated LED	900 lm 900 lm	2700° K 2700° K	Alim. électronique intégrée Integrated power supply	Variation. Veuillez nous contacter Dimming. Please, contact us
--------------------------------	------------------	--------------------	--	---



Designer

Émilie Cathelineau

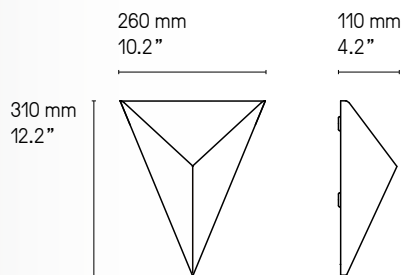

Exemples de compositions
Examples of arrangements

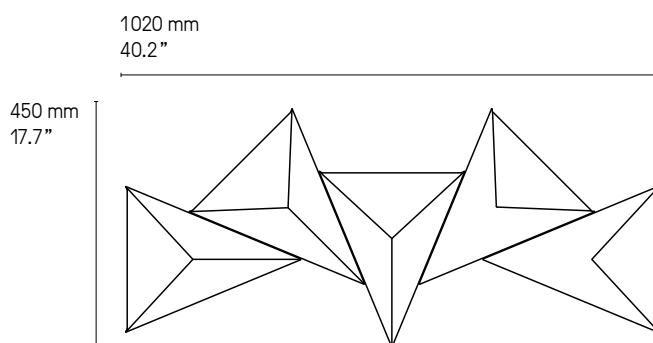
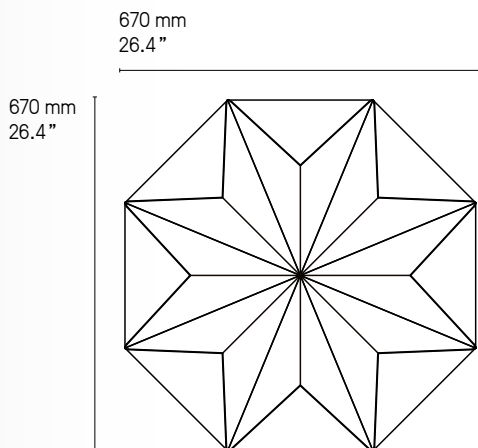
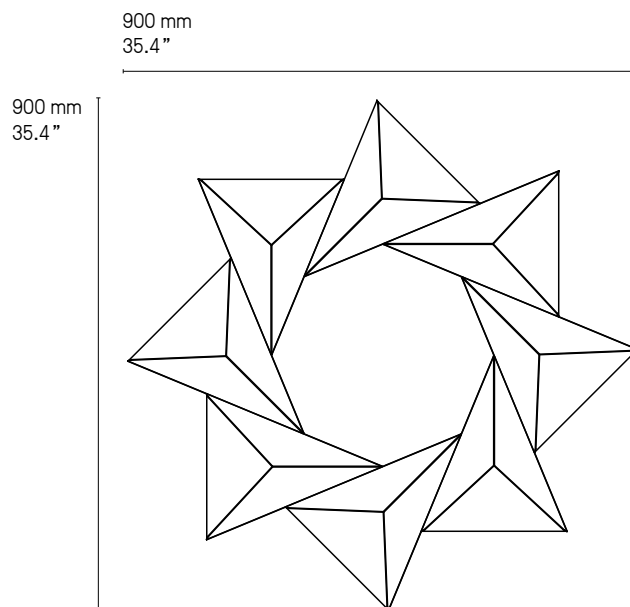
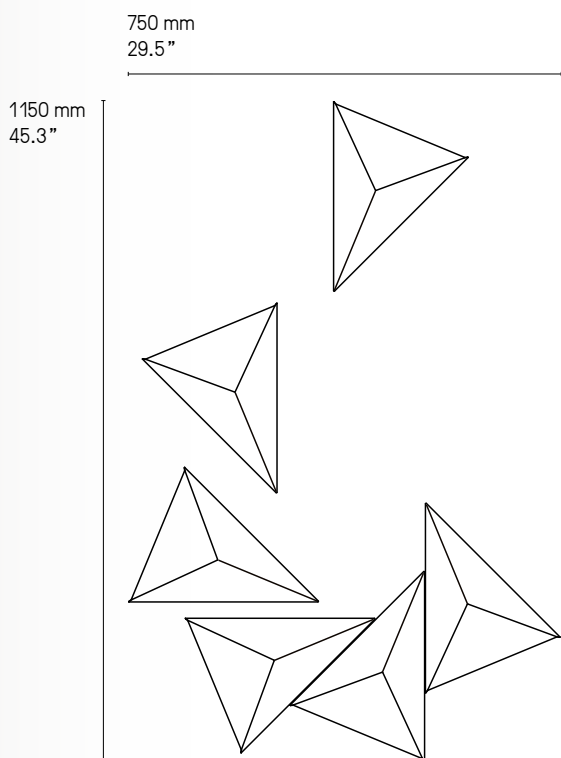





Tetra SB











UPPER

Lampadaire unique aux dimensions généreuses, *Upper* investit l'espace comme un objet à la fois utile et précieux. Inspiré des gratte-ciel de Manhattan, ses lignes invitent le regard à monter vers le ciel.



A unique floor lamp with large dimensions, *Upper* uses space as a valuable and useful object. Tall with straight brass tubes, this light is inspired by Manhattan's skyscrapers.

**Finitions
Finishes**

 Laiton satiné SB Satin brass	 Graphite satiné SG Satin graphite	 Nickel satiné SN Satin nickel	 Cuivre satiné SC Satin copper
 Laiton poli PB Polished brass	 Graphite poli PG Polished graphite	 Nickel poli PN Polished nickel	 Cuivre poli PC Polished copper

**Abat-jour
Lampshade**

 Drop Paper® 100	 Drop Paper® 101	 Drop Paper® 103
---	---	---

**Matériaux
Material**

Laiton massif Solid Brass	Abat-jour Drop Paper® M1 Lampshade Drop Paper® M1	Câble textile noir (longueur ≈ 2 m) Black textile cable (length ≈ 79")
------------------------------	--	---

**Source
Lamping**

3 x E27 70W max. Ampoule non fournie 3 x E27 70W max. Bulb not included	Variateur à pied Foot operated dimmer	Variation* Dimming*
3 x E26 type A 150W. Bulb not included	Foot operated switch	

**Designer**Hervé Langlais

* Les luminaires variables nécessitent l'utilisation d'ampoules compatibles avec la variation
All dimmable light fixture require the use of compatible bulbs

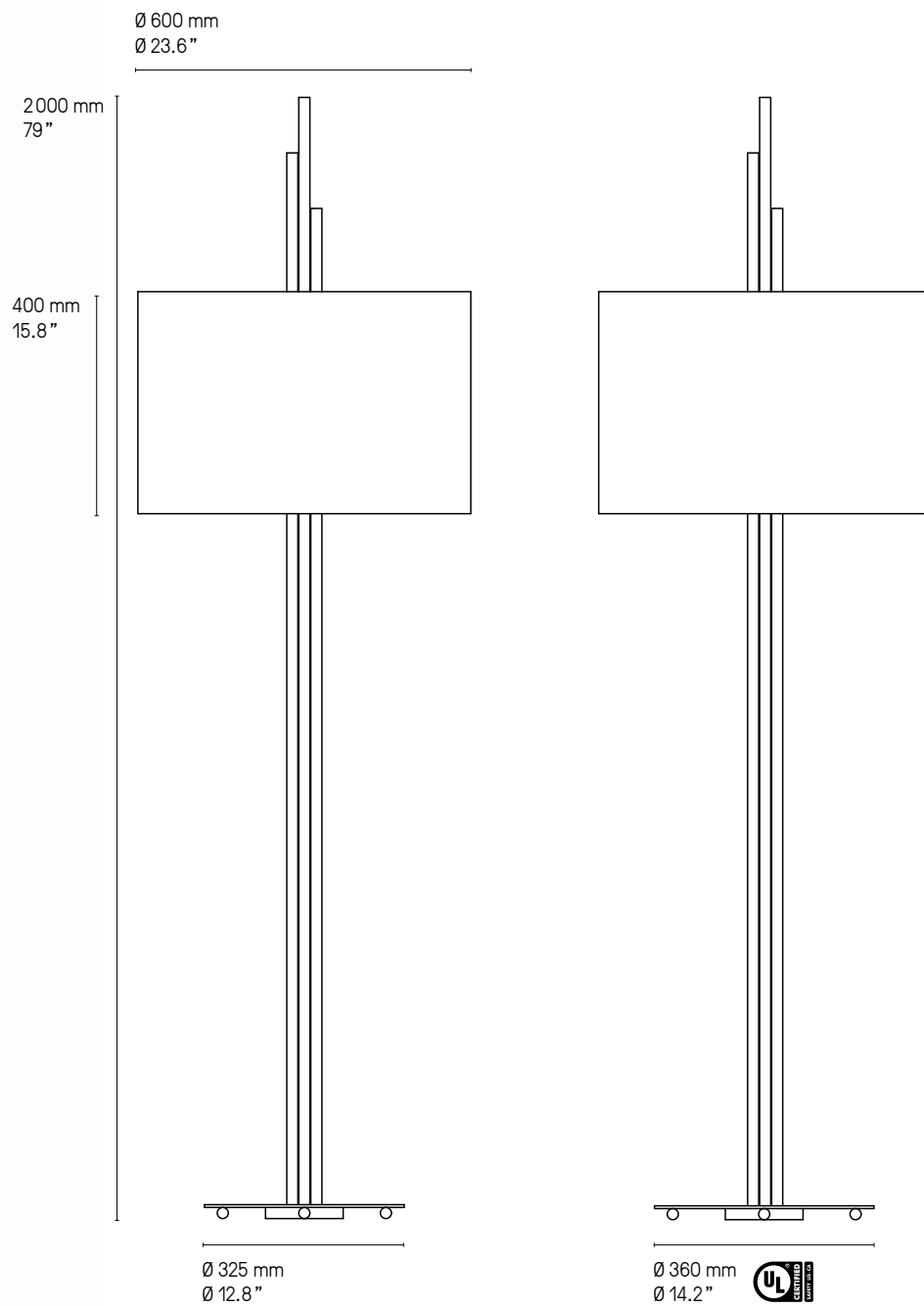

Version LED et DALI sur demande.
LED and DALI version upon request.



W O K



Comme les modèles *Louis* et *Fléa*, la collection d'appliques et lampes *Wok* est dotée d'une verrerie artisanale soufflée bouche. Enveloppée dans une vasque en laiton, elle se personnalise à votre gré.

In the same way as the *Louis* and *Fléa* modules, the collection of wall lights and Lamps *Wok* is provided with hand-blown glass. Wrapped in a brass bowl, you can customize it to suit your fancies.

**Finitions
Finishes**

 Laiton satiné SB Satin brass	 Graphite satiné SG Satin graphite	 Nickel satiné SN Satin nickel	 Cuivre satiné SC Satin copper
--	---	---	---

**Nuances du verre
Glass colors**

 Opale Opal	 Opale et écaille Opal and patterned	 Claire et écaille Clear and patterned
---	--	--

**Matériaux
Material**

Laiton massif Solid Brass	Verrerie soufflée bouche Mouth-blown glass	Câble noir (Lampe) Black cable (Lamp)
------------------------------	---	--

**Source
Lamping**

Applique LED intégrée 1060 lm 2700°K Alim. électronique intégrée Variation. Veuillez nous contacter	Lampe de table LED intégrée 1060 lm 2700°K Alim. électronique intégrée (sur la prise)
Wall light Integrated LED 1060 lm 2700°K Integrated power supply (in backplate) Dimming. Please, contact us	Table lamp Integrated LED 1060 lm 2700°K Integrated power supply (in plug)

Designer

Émilie Cathelineau

Applique – Wall light

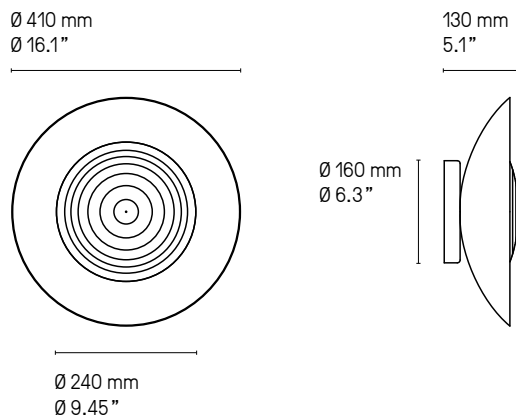

Lampe de table – Table lamp

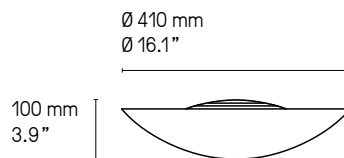



Wok SC Opal and patterned glass



Wok SC Clear and patterned glass











WONDER

Inspirée des lampes de poche de notre enfance, *Wonder* se décline en appliques et en lampes dans un format XL. Un brin de nostalgie dans cette collection aux nombreuses variantes grâce à une gamme de couleurs originales, mariées à nos finitions métalliques













Inspired by our childhood's flashlights, *Wonder* offers a variety of wall lights and XL lamps. An ounce of nostalgia in this wide-ranging collection with several original colors available, combined with metal finishing.

Finitions Finishes ①

 Laiton satiné SB Satin brass	 Graphite satiné SG Satin graphite	 Nickel satiné SN Satin nickel	 Cuivre satiné SC Satin copper
 Laiton poli PB Polished brass	 Graphite poli PG Polished graphite	 Nickel poli PN Polished nickel	 Cuivre poli PC Polished copper

Finitions Finishes ②

 Bleu foncé DB Dark Blue	 Bleu clair LB Light Blue	 Goyave GU Guava	 Bordeau DR Dark Red
 Mangue MA Mango	 Vert vintage VG Vintage Green		
 Laiton satiné SB Satin brass	 Graphite satiné SG Satin graphite	 Nickel satiné SN Satin nickel	 Cuivre satiné SC Satin copper

Matériaux Material

Tous – All Laiton massif et acier peint Solid Brass and painted steel	Diffuseur PMMA blanc texturé Textured white PMMA diffuser	Lampe de Table – Table Lamp Câble textile noir Black textile cable
--	--	---

Source Lamping

Lampe de table – Table lamp LED 1100 lm 2700°K	Alim. intégrée 110-220V Power supply 110-220V	Variable Dimmable
Appliques – Wall lights LED 430 lm 2700°K	230V direct 120V direct	Variable (phase cut) Dimmable (phase cut)

Designer

Émilie Cathelineau

Applique XS V1 – Wall light XS V1

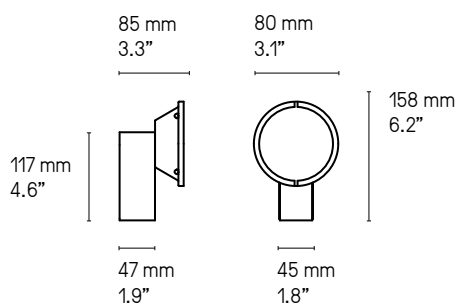

Applique XS V2 – Wall light XS V2

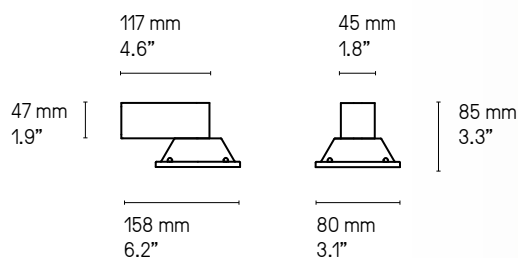

Les appliques Wonder ne sont pas réglables. V1 et V2 sont des modèles différents.
Wonder wall lights are not mobile. V1 and V2 are different fixed models.

Applique XL V1 – Wall light XL V1

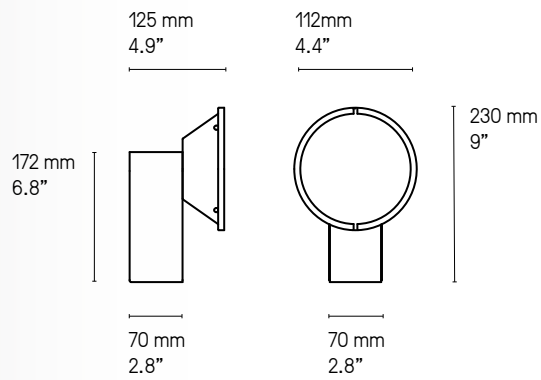

Applique XL V2 – Wall light XL V2

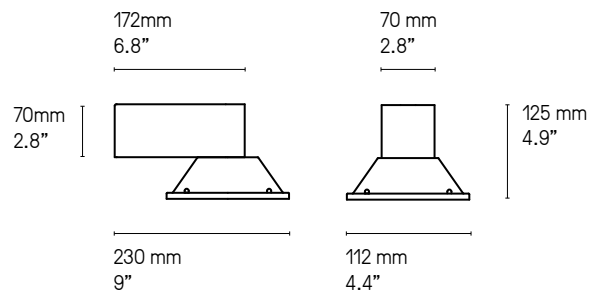

Lampe de table – Table lamp

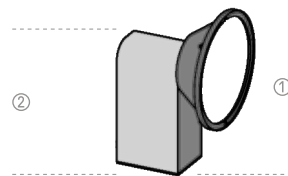
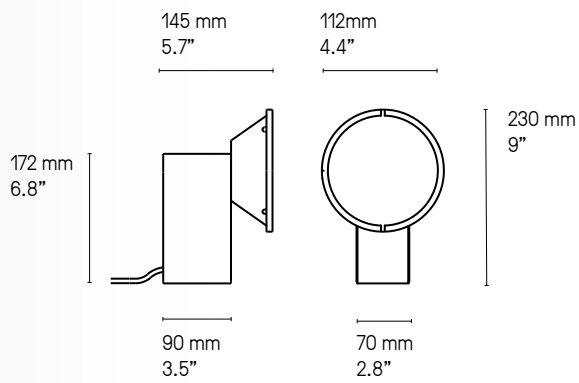

Lampes de table – Table lamps

- | | |
|----------------|----------------|
| A Wonder PB/SG | E Wonder SG/SB |
| B Wonder PG/MA | F Wonder SN/LB |
| C Wonder PN/DR | G Wonder SB/DB |
| D Wonder SB/GU | H Wonder SG/VG |

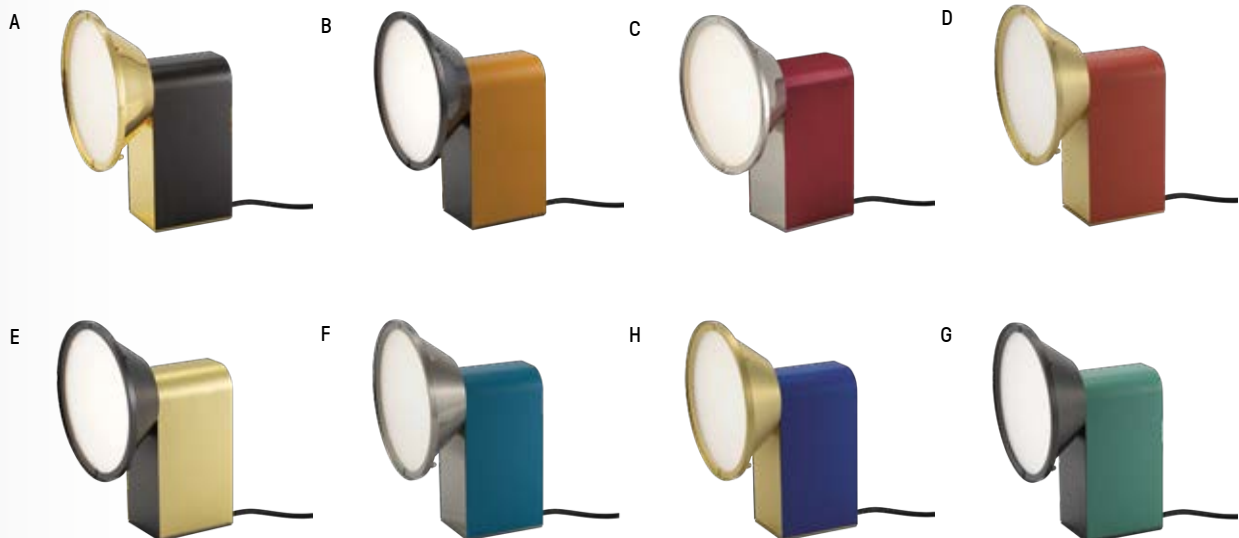

NUANCIER - FINISH OPTIONS



LAITON - BRASS

- | | |
|-------------------------------------|---|
| ① Laiton satiné
SB Satin brass | ② Graphite satiné
SG Satin graphite |
| ③ Nickel satiné
SN Satin nickel | ④ Cuivre satiné
SC Satin copper |
| ⑤ Laiton poli
PB Polished brass | ⑥ Graphite poli
PG Polished graphite |
| ⑦ Nickel poli
PN Polished nickel | ⑧ Cuivre poli
PC Polished copper |

ABAT-JOURS - LAMPSHADES



Drop Paper® 100



Drop Paper® 101

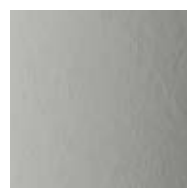

Drop Paper® 103

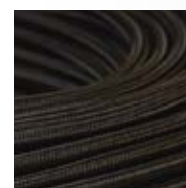

Tissu noir
Black textile



Chinette blanche
White chinette



Chinette noire
Black chinette

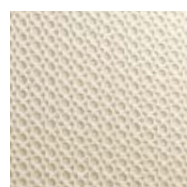

Duke
Duke



Tissu or
Gold textile

VERRERIE - GLASS



Opale
Opal



Opale et écaïlle
Opal and patterned

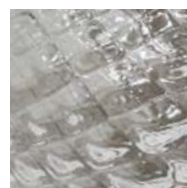

Claire et écaïlle
Clear and patterned

CONSEILS TECHNIQUES

Les caractéristiques techniques mentionnées dans ce document sont données à titre indicatif et sont susceptibles de subir des modifications. Ceci est lié à l'évolution rapide de la technologie LED.

Les dimensions sont approximatives et peuvent varier légèrement.

AMPOULES

Il est impératif de respecter les types et les puissances maximales préconisées sous peine de détériorer le luminaire. En cas de non-respect, la garantie ne pourra s'appliquer.

CONSEIL D'ENTRETIEN

Essuyage avec un chiffon doux, sans produits d'entretien. Nos produits étant vernis afin d'assurer la longévité du luminaire, il ne faut en aucun cas utiliser de produits détergents ou de solvants.

La société se réserve le droit de modifier, sans préavis, les caractéristiques de ses produits.

TECHNICAL ADVICE

The technical characteristics provided in this document are for information purposes only and are subject to change, due to permanent evolution of LED technology.

All dimensions are approximate and may vary slightly.

LIGHT BULBS

Use only the type of light bulb and maximum wattage shown otherwise you may damage the light fitting. Failure to use the correct light bulb and wattage will affect the warranty.

CARE INSTRUCTIONS

Wipe with a soft cloth –do not use any cleaning products. All our light fittings are lacquered to ensure the longevity of the product– under no circumstances use detergents or solvents.

The company reserves the right to modify its products at any time without notice.

Logotype, charte graphique et direction artistique : POOL
Réalisation, suivi de fabrication : deuxpointdeux
Prises de vue, intégrations 3D : Garnier Studios, sauf p.113 et p.133 : CVL
Photos d'ambiance : p.8, Francis Amiand pour Stéphanie Coutas architecte d'intérieur ; p.20-21, 3mille pour Kelly Boukobza architecte ; p.28, Morgane Le Gall pour Lelievre Paris ; p.32 & 70-71, Magalie Terzian architecte pour Hôtel Genovese Bonifacio ; p.53, Agence Kappel pour Hôtel Les roches blanches Cassis ; p.55, Géraldine Meurisse décoratrice d'intérieur pour Hôtel Cardinal Bordeaux ; p.80-81, Jan Schuenke pour Hôtel Waldorf Astoria Beverly Hills
Ambiance 3D p.130 : Vincent Poinas
Portraits : Garnier Studios (É. Cathelineau), Stephanie Füssenich (P. Deltour), Yannick Labrousse (POOL), droits réservés (K. Gavaille, H. Langlais)
Schémas techniques : Émilie Cathelineau
Textes : Valérie Marion – BIGRE, sauf présentation CVL : Catherine Deydier
Traductions : International MCM
Impression : SETIG

Logo, brand identity and art direction: POOL
Layout, print process supervision: deuxpointdeux
Photo shoots, 3D integrations: Garnier Studios, except p.113 and p.133: CVL
Lifestyle photos: p.8, Francis Amiand for interior designer Stephanie Coutas; p.20-21, 3mille for architect Kelly Boukobza; p.28, Morgane Le Gall for Lelievre Paris; p.32 & 70-71, architect Magalie Terzian for Genovese Hotel Bonifacio; p.53, Kappel Agency for Les roches blanches Hotel Cassis; p.55, interior designer Géraldine Meurisse for Cardinal Hotel Bordeaux; p.80-81, Jan Schuenke for Waldorf Astoria Hotel Beverly Hills
3D Lifestyle p.130: Vincent Poinas
Portraits: Garnier Studios (É. Cathelineau), Stephanie Füssenich (P. Deltour), Yannick Labrousse (POOL), rights reserved (K. Gavaille, H. Langlais)
Technical drawings: Émilie Cathelineau
Texts: Valérie Marion – BIGRE (except CVL introduction: Catherine Deydier)
Translation: International MCM
Printing: SETIG

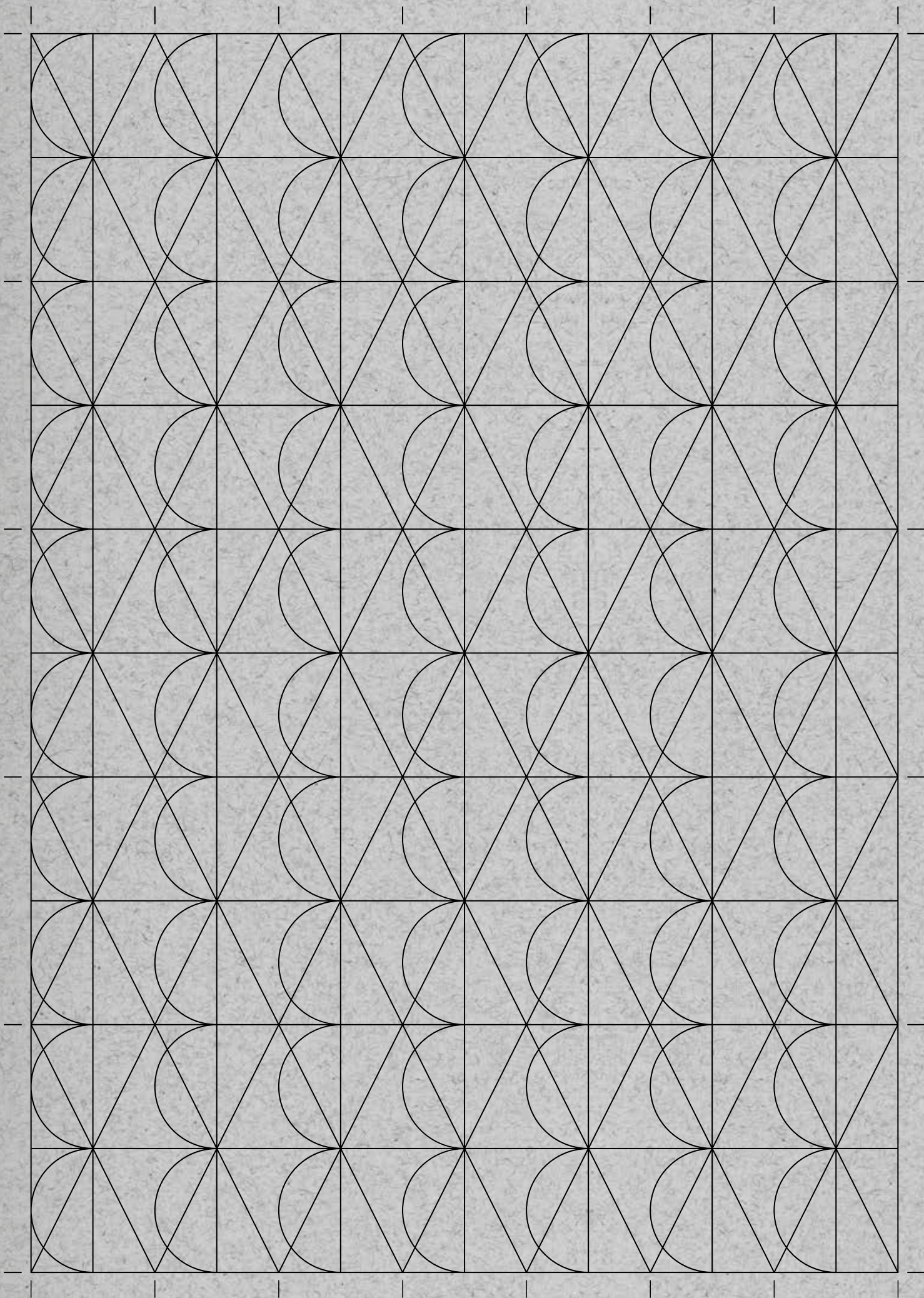

CVL LUMINAIRES

79 ROUTE DE LA CHEVALLERIE - 49770 LONGUENÉE-EN-ANJOU - FRANCE
TEL. +33 (0) 2 41 32 67 54 - FAX +33 (0) 2 41 32 76 62
EMAIL : CONTACT@CVL-LUMINAIRES.FR

WWW.CVL-LUMINAIRES.FR